Wall hung, fan flue, room sealed gas boiler

SERVICE MANUAL

RIVA PLUS

Models: G.C. Appl. No.

M90D.24S 47-970-15

M90D.28S 47-970-16

M90D.24SR 41-970-08

M90D.28SR 41-970-09

Leave this manual adjacent to the gas meter

Biasi U.K. Ltd
Unit 31/33, Planetary Road
Industrial Estate, Neachells Lane
Willenhall, Wolverhampton WV 13 3XB
Technical helpline: 01902 304 400
Web site: www.biasi.co.uk

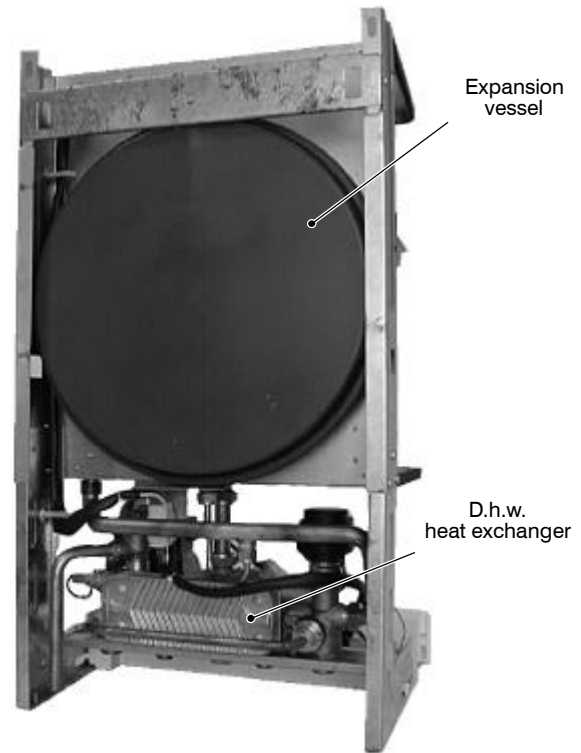
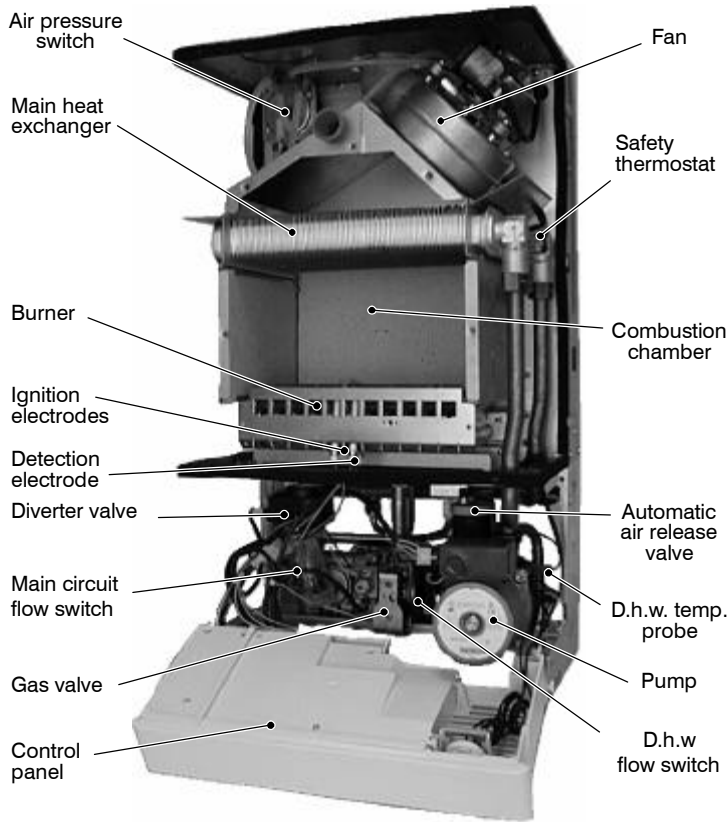

Table of contents

1	Overall information	2	11	Modulating gas valve	27
1.1	Overall View	2	11.1	Function	27
1.2	Hydraulic diagram	2	11.2	Nomenclature of the parts	27
2	General access and emptying hydraulic circuits	3	11.3	Adjustment	27
2.1	Nomenclature	3	11.4	Checks	28
2.2	Body panels	3	11.5	Removal of the on–off operators coils	28
2.3	Control panel	3	11.6	Removal of the gas valve	28
2.4	Access to the sealed chamber	4	12	Primary circuit flow switch	29
2.5	Emptying the primary circuit	4	12.1	Function	29
2.6	Emptying the d.h.w. circuit	4	12.2	Checks	29
3	Diagrams	5	12.3	Removal	29
3.1	Wiring diagram M90D.24S M90D.28S	5	13	Expansion vessel and temperature–pressure gauge	30
3.2	Wiring diagram M90D.24SR, M90D.28SR	7	13.1	Function	30
3.3	Functional flow diagrams	9	13.2	Checks	30
3.4	Circuit voltages	10	13.3	Removal of the expansion vessel	30
4	Fault finding	12	13.4	Removal of the temperature–pressure gauge	30
5	Primary heat exchanger	14	14	D.h.w. flow switch, filter and flow limiter	31
5.1	Characteristics	14	14.1	Function	31
5.2	Removal	14	14.2	Nomenclature and location of parts	31
5.3	Cleaning	14	14.3	Checks	31
6	D.h.w. heat exchanger	15	14.4	Removal of the flow switch sensor	31
6.1	Function	15	14.5	Removal of the flow switch group and d.h.w. circuit filter	31
6.2	Removal	15	14.6	Flow limiter	32
7	Pump	16	15	Temperature probe	33
7.1	Function	16	15.1	Function	33
7.2	Checks	16	15.2	Checks	33
7.3	Removal	16	15.3	Removal	33
8	Three way diverter valve	17	16	By–pass valve	34
8.1	Function	17	16.1	Function	34
8.2	Checks	17	16.2	Removal	34
8.3	Removal of the electric actuator	17	17	Fan, venturi device and Air pressure switch	35
8.4	Removal of the diverter group and its internal parts	18	17.1	Function	35
9	Electronic control p.c.b.	19	17.2	Checks	35
9.1	Function	19	17.3	Removal of the Fan	36
9.2	Selection and adjustment devices	19	17.4	Inspection and removal of the venturi device	36
9.3	Checking the temperature	19	17.5	Removal of the Air pressure switch	37
9.4	Operation lights	20	18	Ignition and detection electrodes	38
9.5	Dip–switch selectors	21	18.1	Function	38
9.6	Setting jumpers	22	18.2	Checks	38
9.7	Ignition gas pressure adjustment	22	18.3	Removal	38
9.8	Max c.h. power adjustment	22	19	Safety thermostat	39
9.9	Checks	22	19.1	Function	39
9.10	Removal of the electronic control p.c.b.	22	19.2	Checks	39
9.11	Thermal control in the "❄️" mode	24	19.3	Removal	39
9.12	Thermal control in the "☀️" mode	24	20	Short spare parts list	40
10	Full sequence ignition device	25			
10.1	Function	25			
10.2	Checks	25			
10.3	Removal	25			
10.4	Ignition and control sequence	26			

1 Overall information

1.1 Overall View



1.2 Hydraulic diagram

Central heating (c.h.) operation

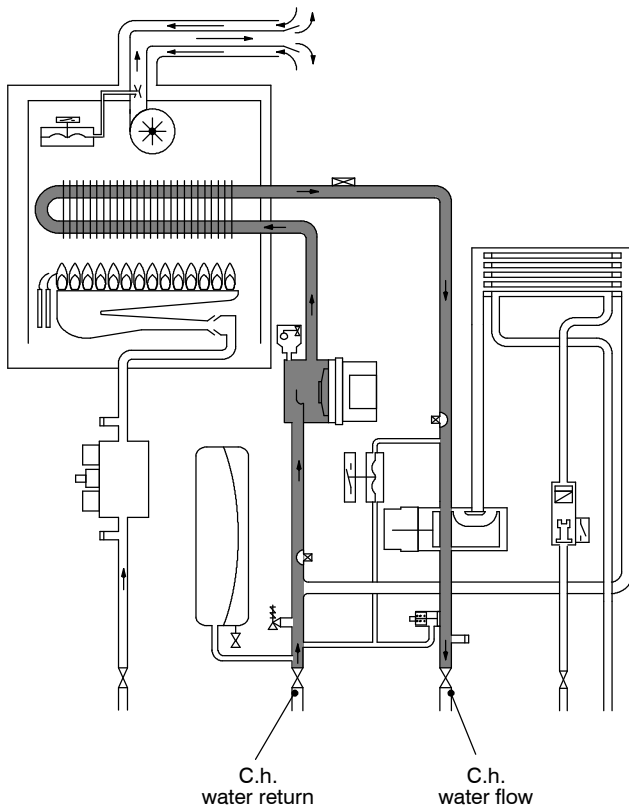

Domestic hot water (d.h.w.) operation

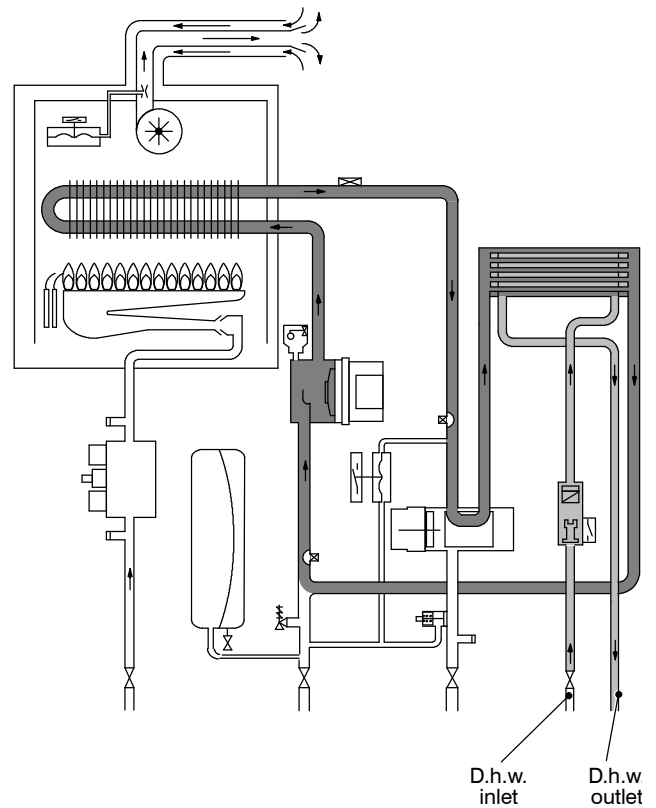

2 General access and emptying hydraulic circuits

2.1 Nomenclature

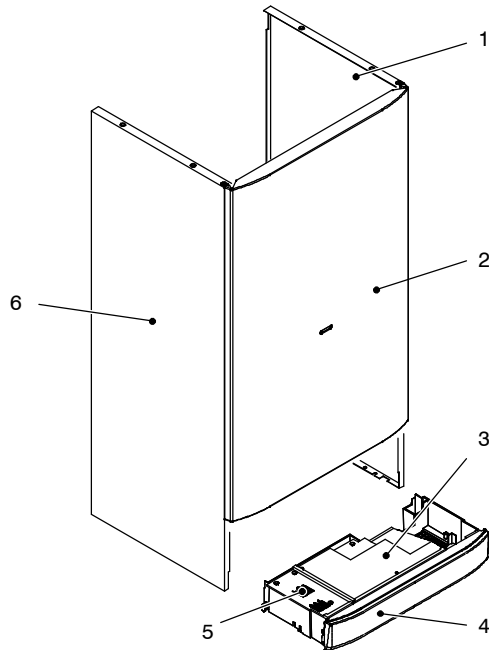

Fig. 1

- 1 Right side panel
- 2 Front panel
- 3 Control panel lid
- 4 Control panel cover
- 5 Service panel
- 6 Left side panel

2.2 Body panels

Warning: isolate the boiler from the mains electricity supply before removing any covering or component.

For the most part of the check and maintenance operations it is necessary to remove one or more panels of the case.

The side panels can be removed only after the removal of the front panel.

To remove the front panel remove screws A (Fig. 2), lift the panel and remove it.

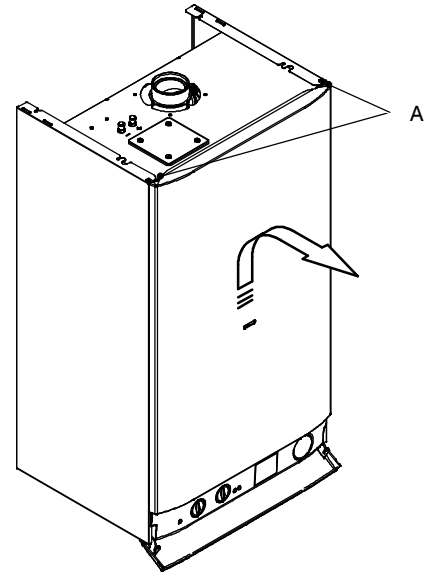

Fig. 2

To remove the side panels loosen the screws B and C (Fig. 3), bring the base of the panels away from the boiler and lift them, freeing them from the top hooks.

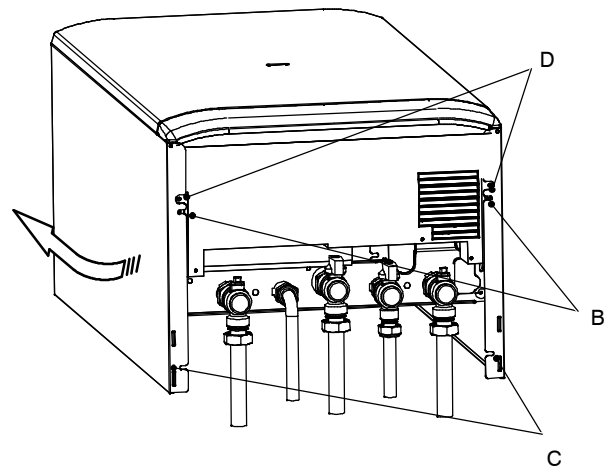

Fig. 3 – bottom view of the boiler

2.3 Control panel

Warning: isolate the boiler from the mains electricity supply before removing any covering or component.

To gain access to the parts located inside the control panel proceed as follows:

- 1 Remove the front panel of the case
- 2 Loosen the screws B and C (Fig. 3).
- 3 Remove the screws D
- 4 Move the lower part of the side panels as indicated in Fig. 4 and pull the control panel. When completely pulled out, the panel can rotate 45° downwards to facilitate the service operations on the internal parts.

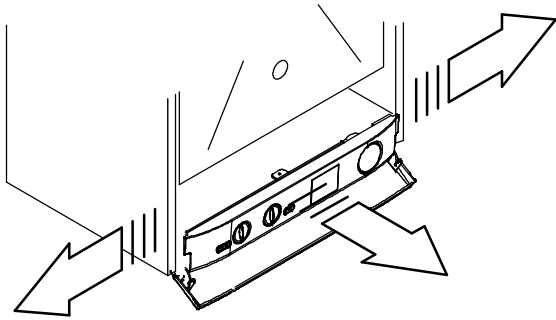

Fig. 4

- 5 Remove the screws *E* and remove the service panel (Fig. 5);
- 6 To gain access to the electronic regulation PCB and the full sequence ignition device remove the screws *F* and remove the control panel lid (Fig. 5);

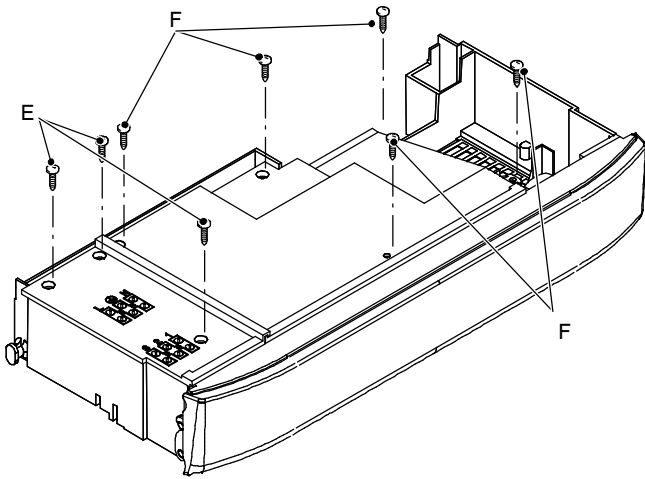

Fig. 5

2.4 Access to the sealed chamber

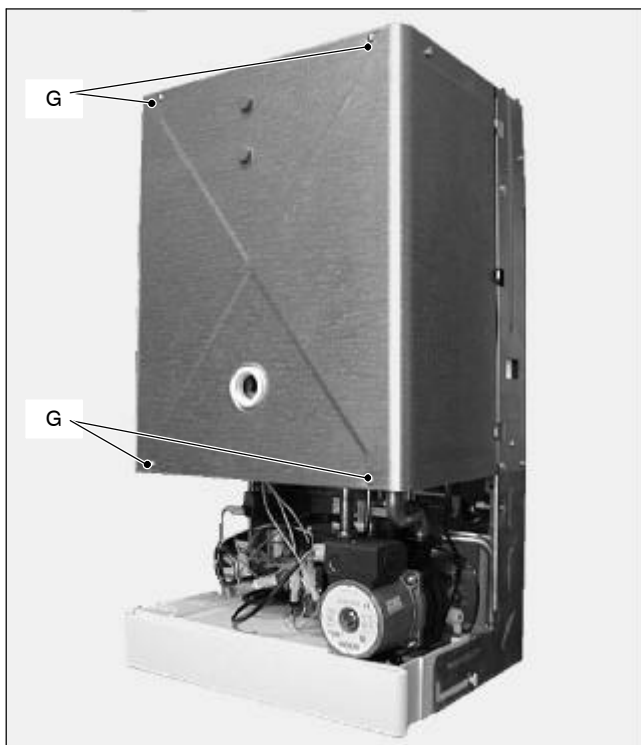

Fig. 6

To gain access to the parts contained in the sealed chamber it is necessary to remove the lid of the sealed chamber.

For this purpose, remove the front and side panels of the case, remove the screws *G* as indicated in Fig. 6 and remove the lid.

2.5 Emptying the primary circuit

- 1 Close the c.h. circuit flow and return cocks *H*. (Fig. 7).

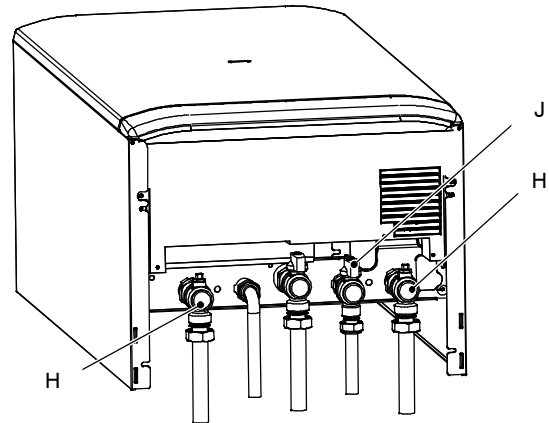

Fig. 7 – bottom view of the boiler

- 2 Remove the front and right panels of the boiler.
- 3 Open the drain tap *I* (Fig. 8) until the boiler is completely emptied.
- 4 Close drain tap again once the emptying has been completed.



Fig. 8

2.6 Emptying the d.h.w. circuit

- 5 Close the d.c.w. inlet cock *J* (Fig. 7);
- 6 Open one or more hot water taps until the boiler has been completely emptied.

3 Diagrams

3.1 Wiring diagram M90D.24S M90D.28S

Wiring diagram for boiler equipped with full sequence ignition device type: Bertelli & Partners FM30

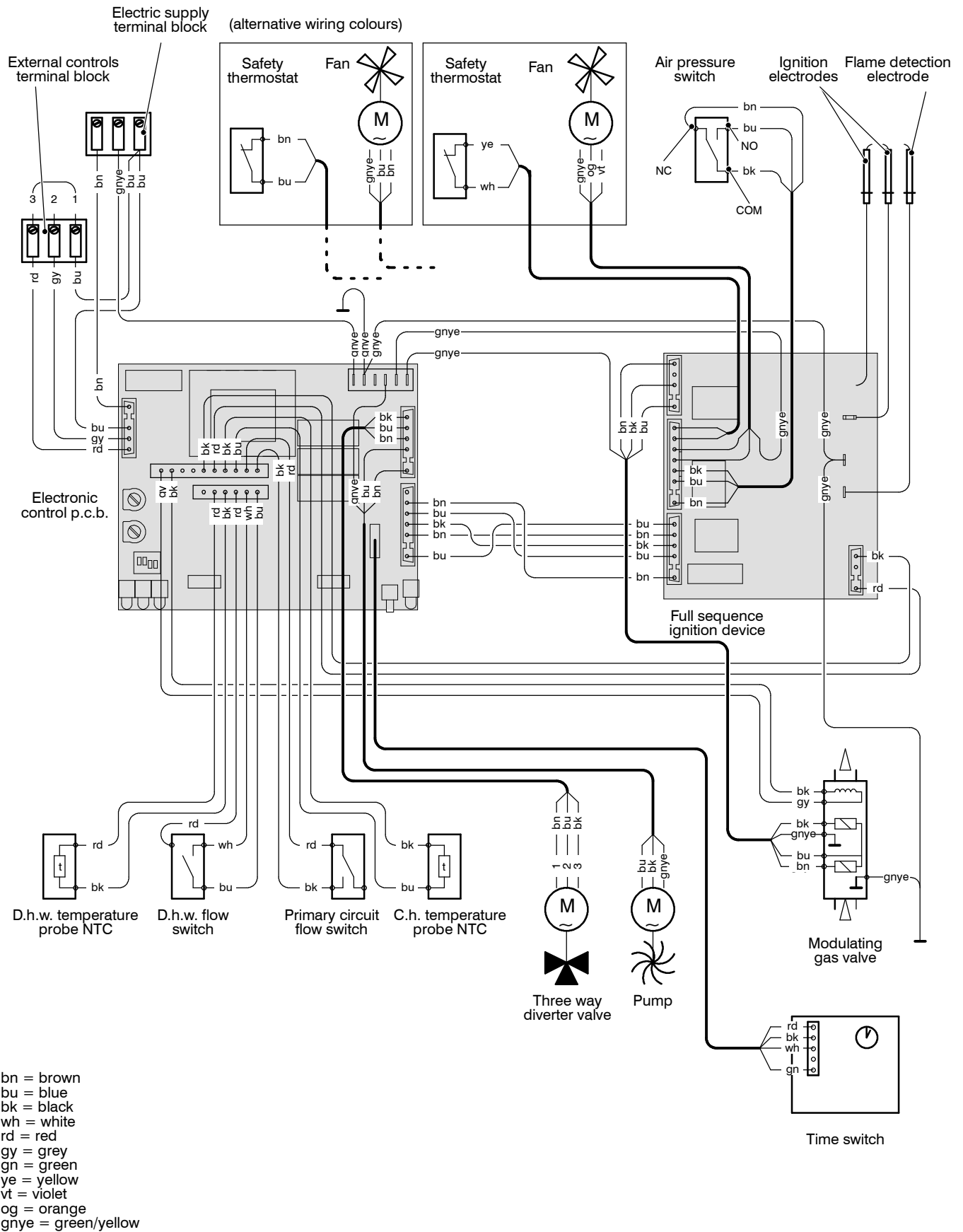

Wiring diagram for boiler equipped with full sequence ignition device type: Honeywell FPLD

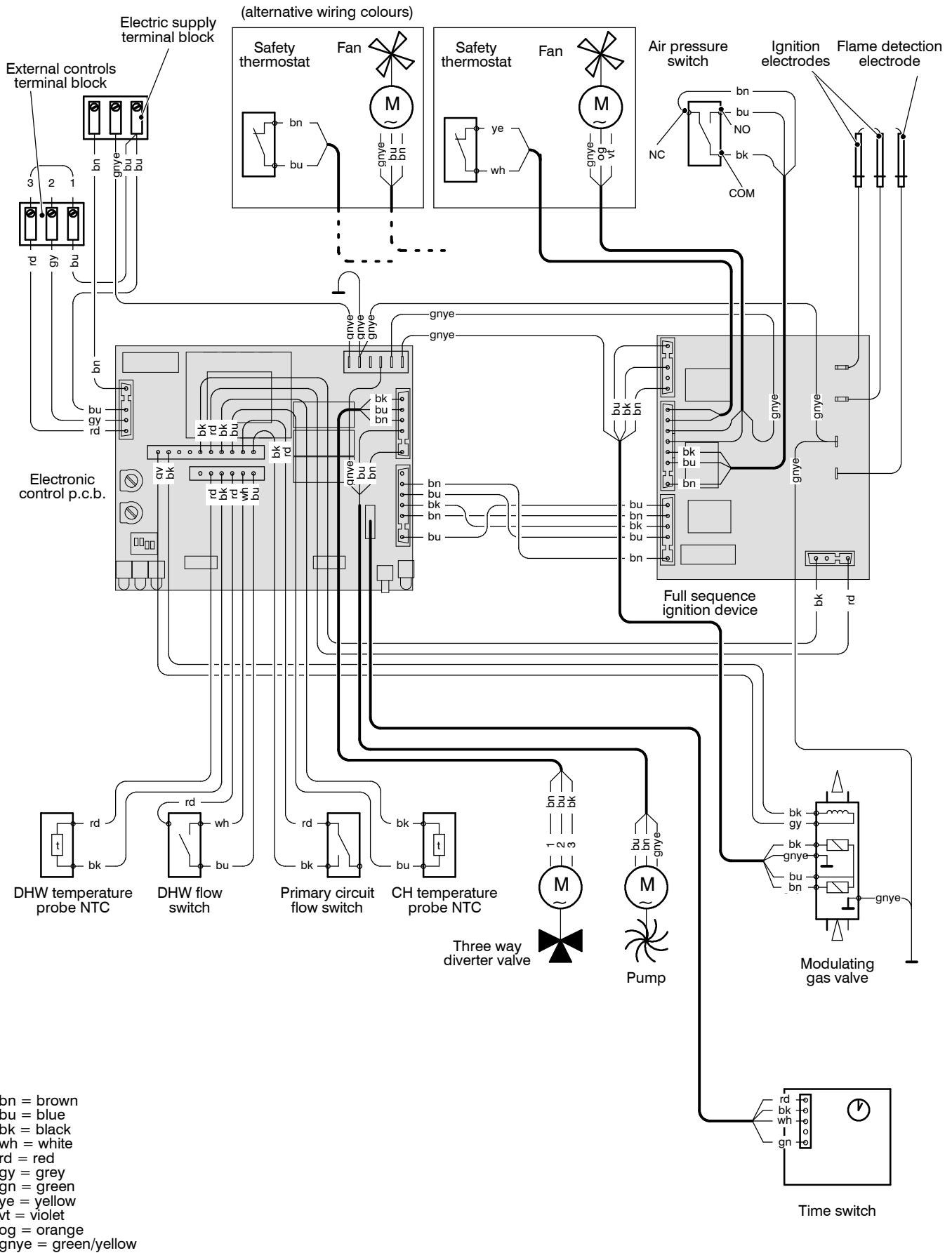

3.2 Wiring diagram M90D.24SR, M90D.28SR

Wiring diagram for boiler equipped with full sequence ignition device type: Bertelli & Partners FM30

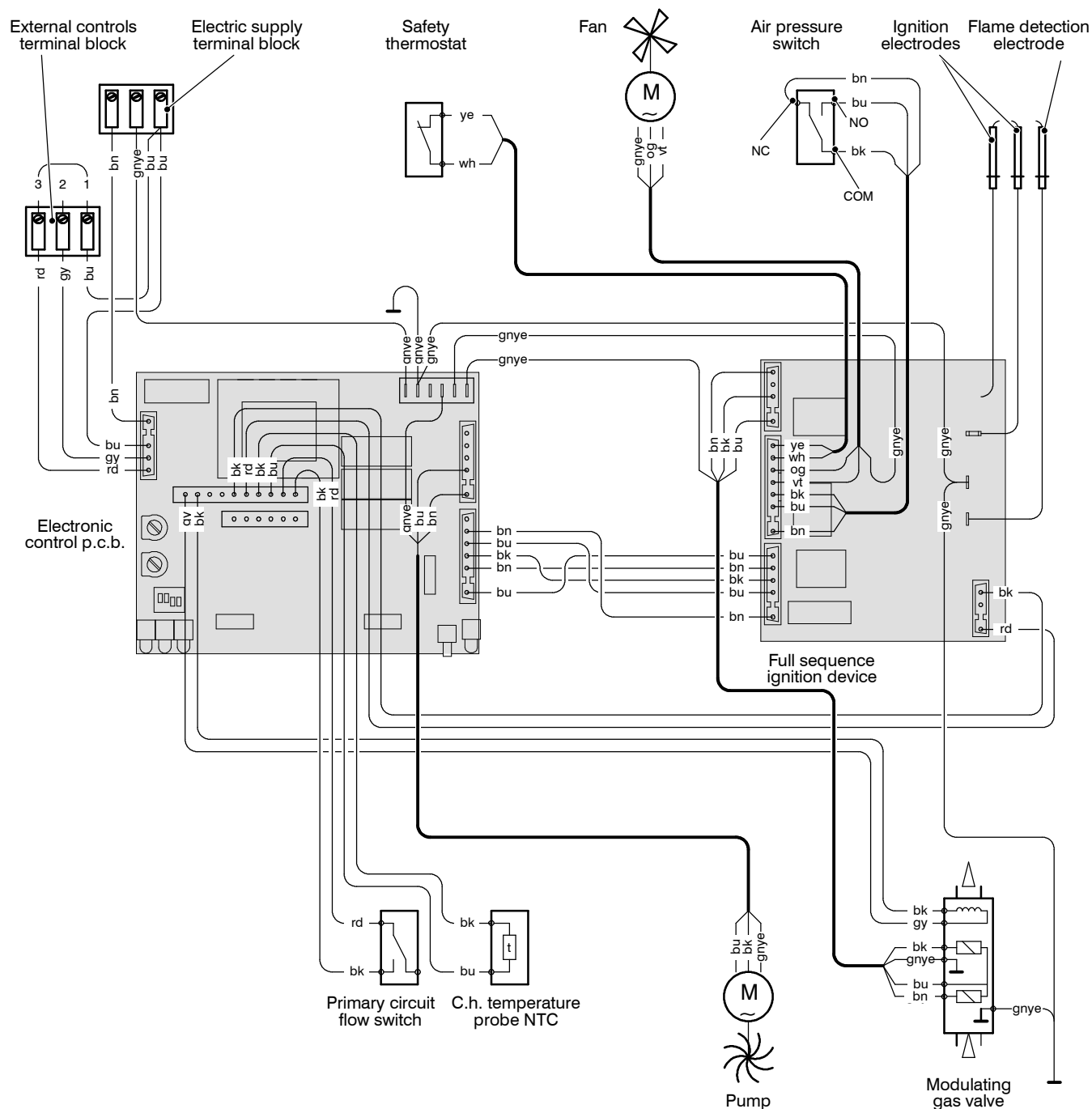

bn = brown
 bu = blue
 bk = black
 wh = white
 rd = red
 gy = grey
 gn = green
 ye = yellow
 vt = violet
 og = orange
 gnye = green/yellow

Wiring diagram for boiler equipped with full sequence ignition device type: Honeywell FPLD

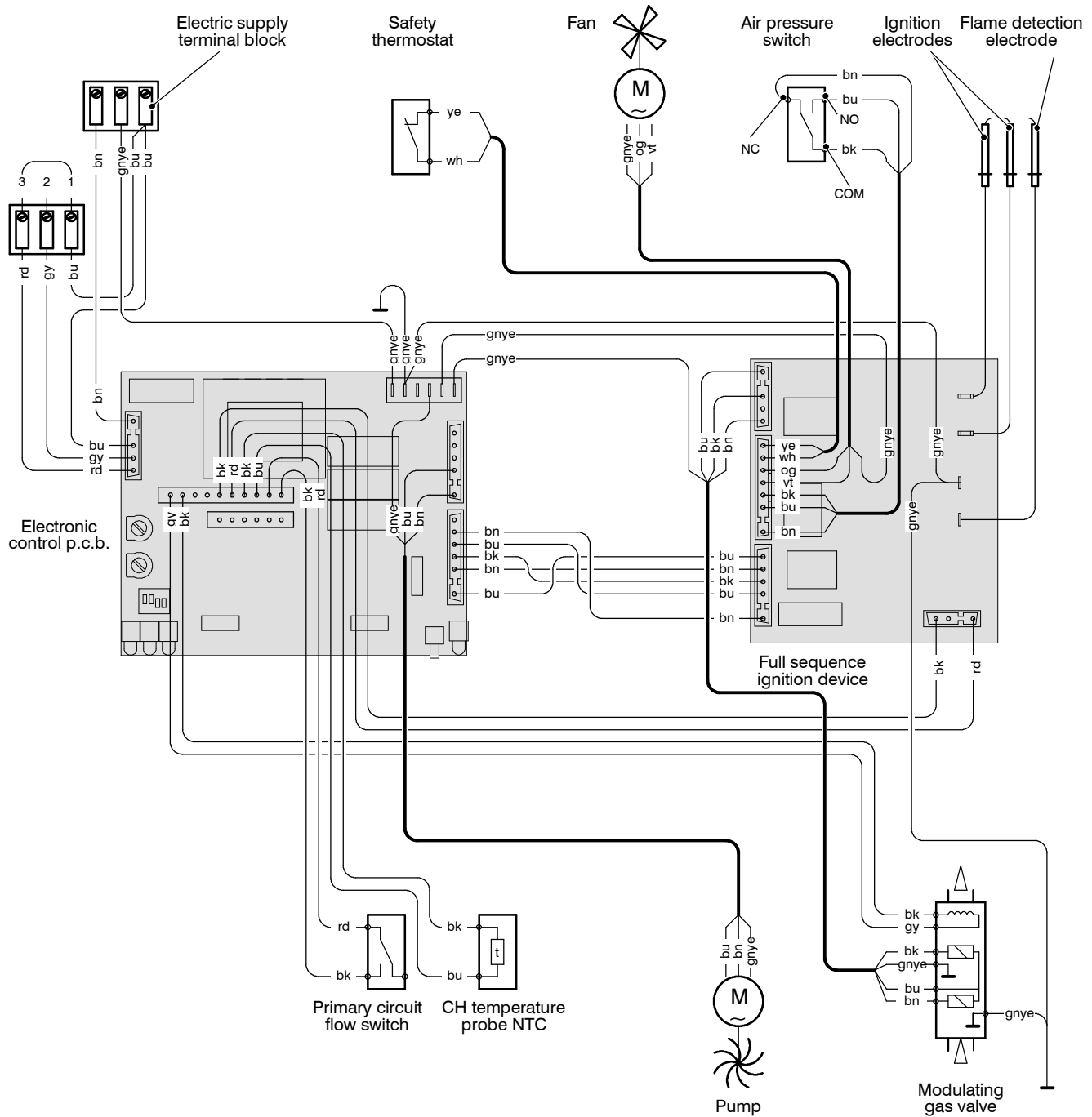

- bn = brown
- bu = blue
- bk = black
- wh = white
- rd = red
- gy = grey
- gn = green
- ye = yellow
- vt = violet
- og = orange
- gnye = green/yellow

3.3 Functional flow diagrams

General layout

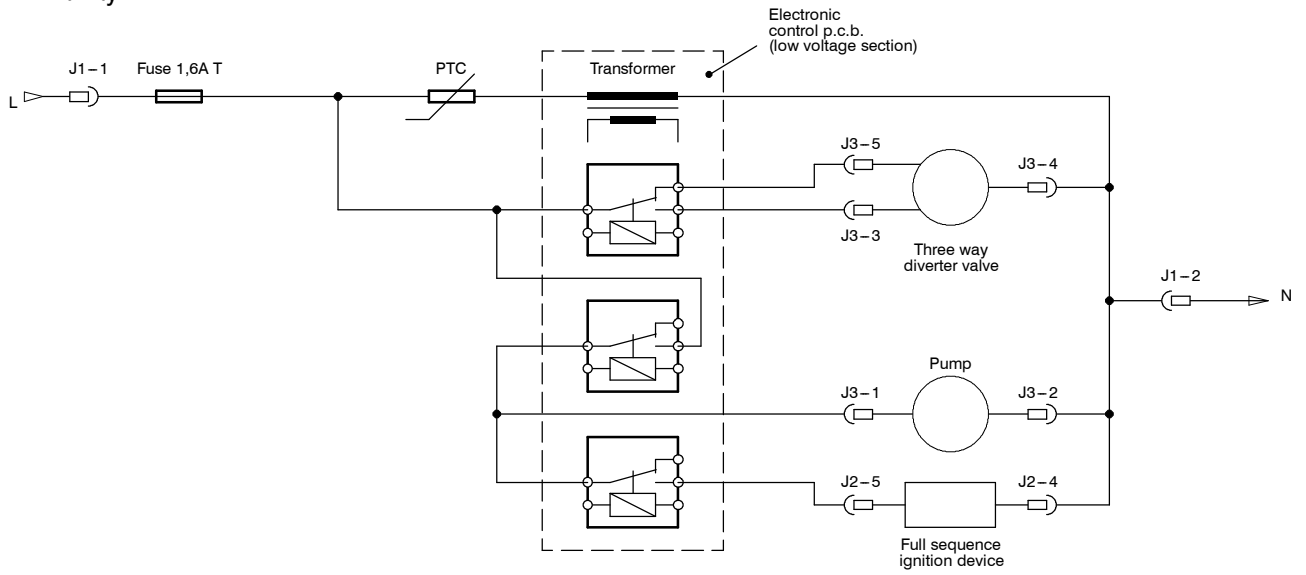

Heat request on d.h.w.

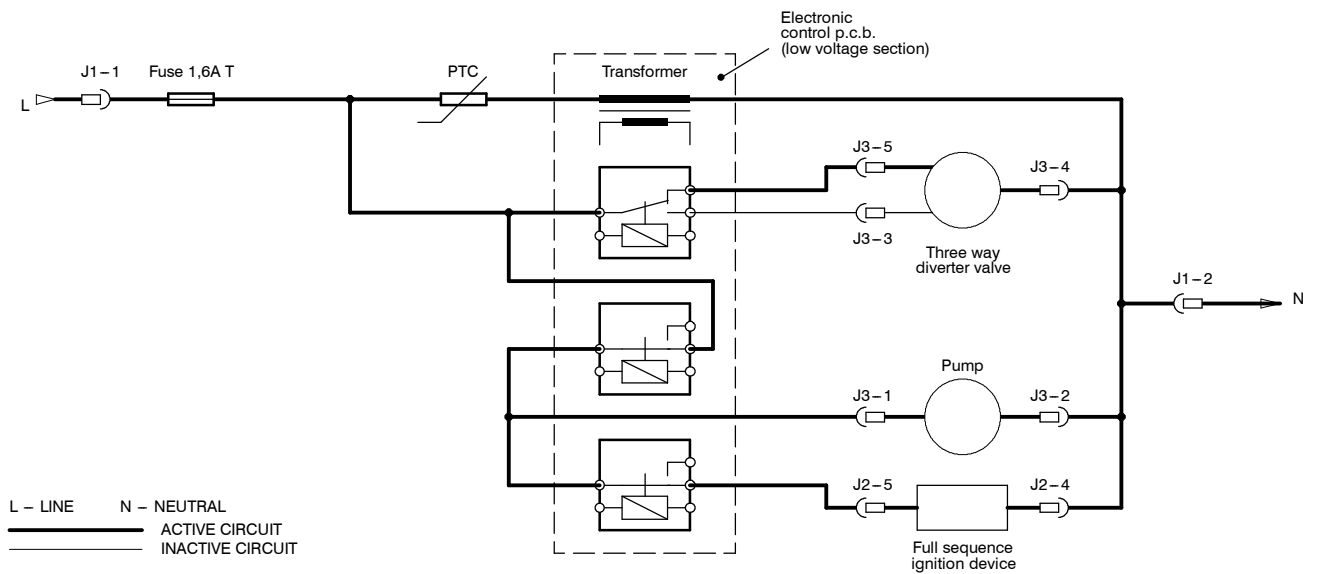

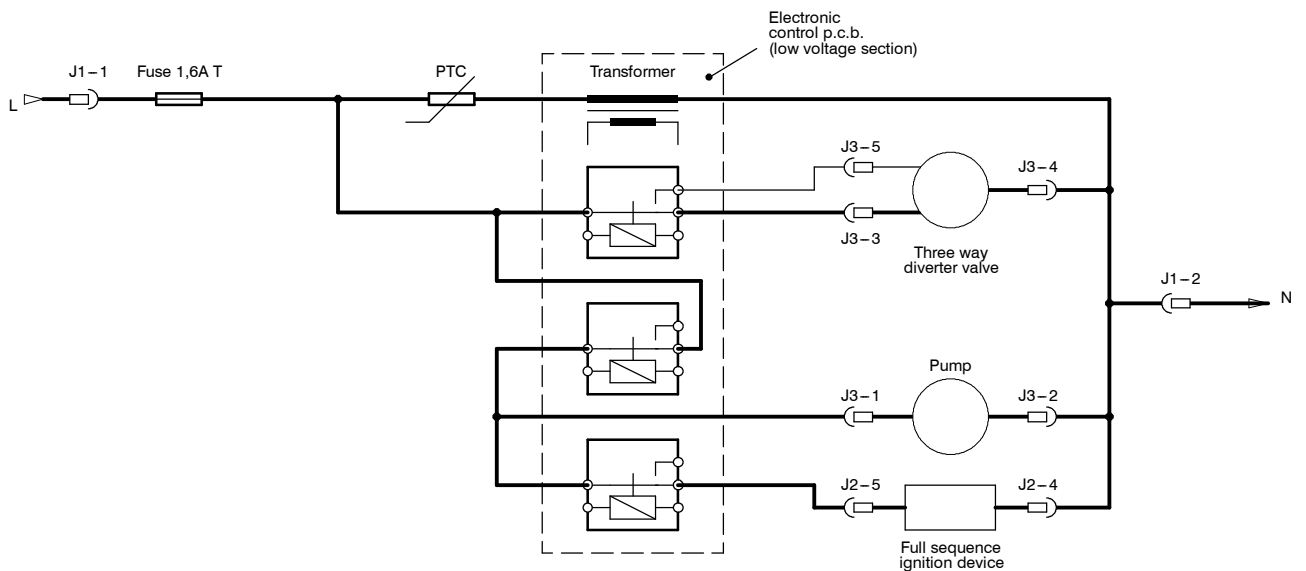

Heat request on c.h.



3.4 Circuit voltages

Diagrams for boiler equipped with full sequence ignition device type: Bertelli & Partners FM30

Electrical voltages with burner on

-  during c.h. or d.h.w. operation
-  only during **c.h.** operation
-  only during **d.h.w.** operation

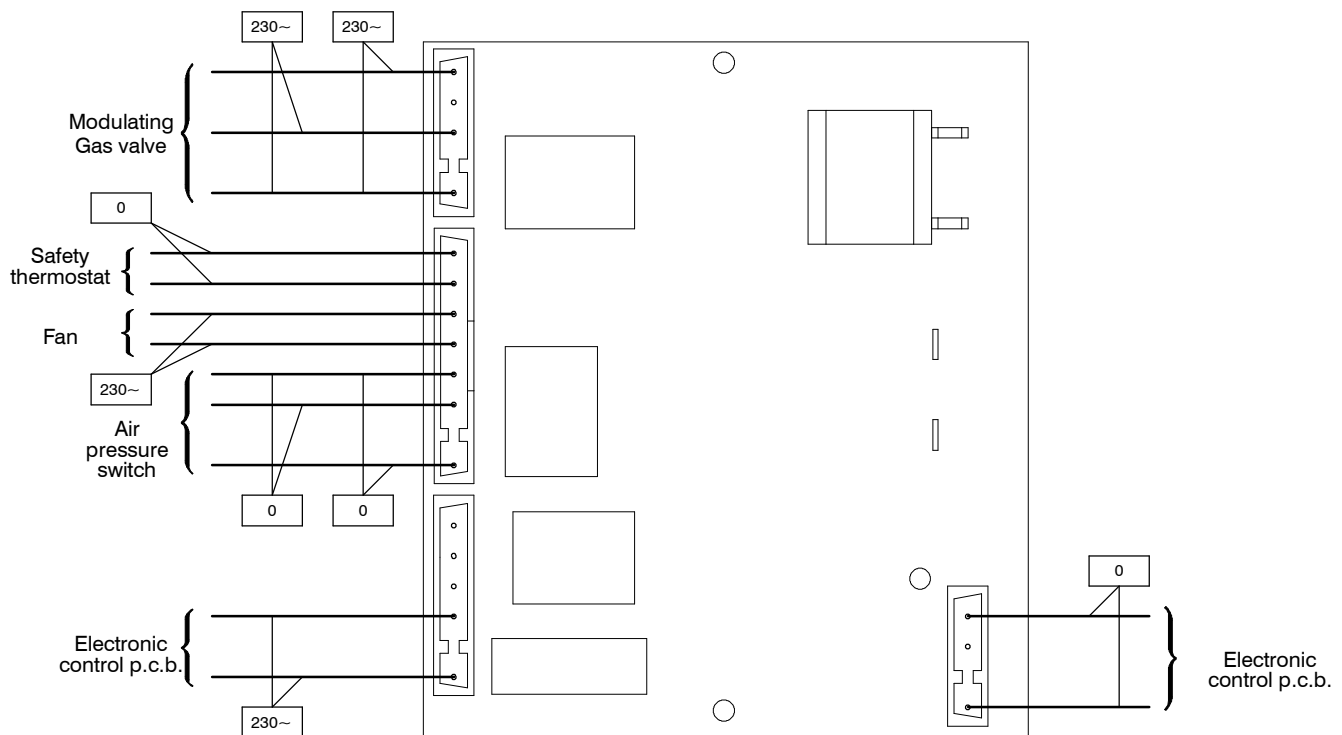
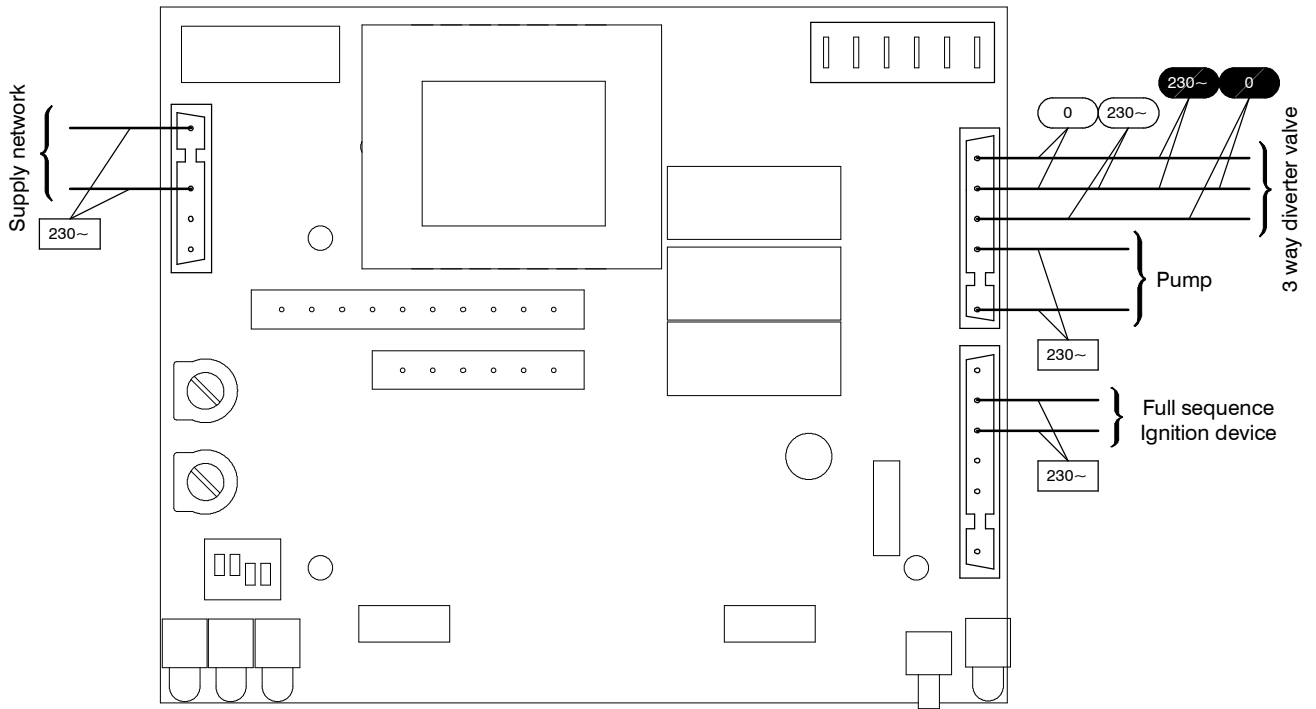

Diagrams for boiler equipped with full sequence ignition device type: Honeywell FPLD

Electrical voltages with burner on

- during c.h. or d.h.w. operation
- only during **c.h.** operation
- only during **d.h.w.** operation

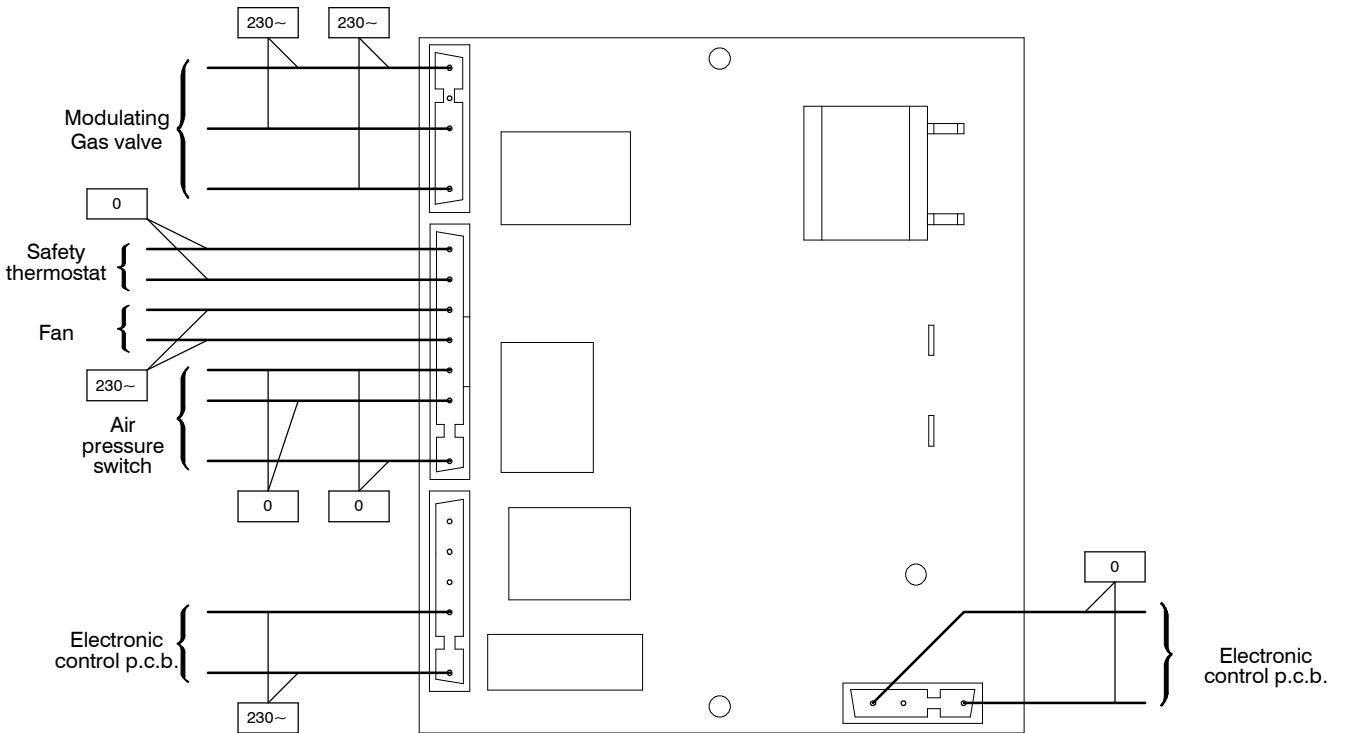
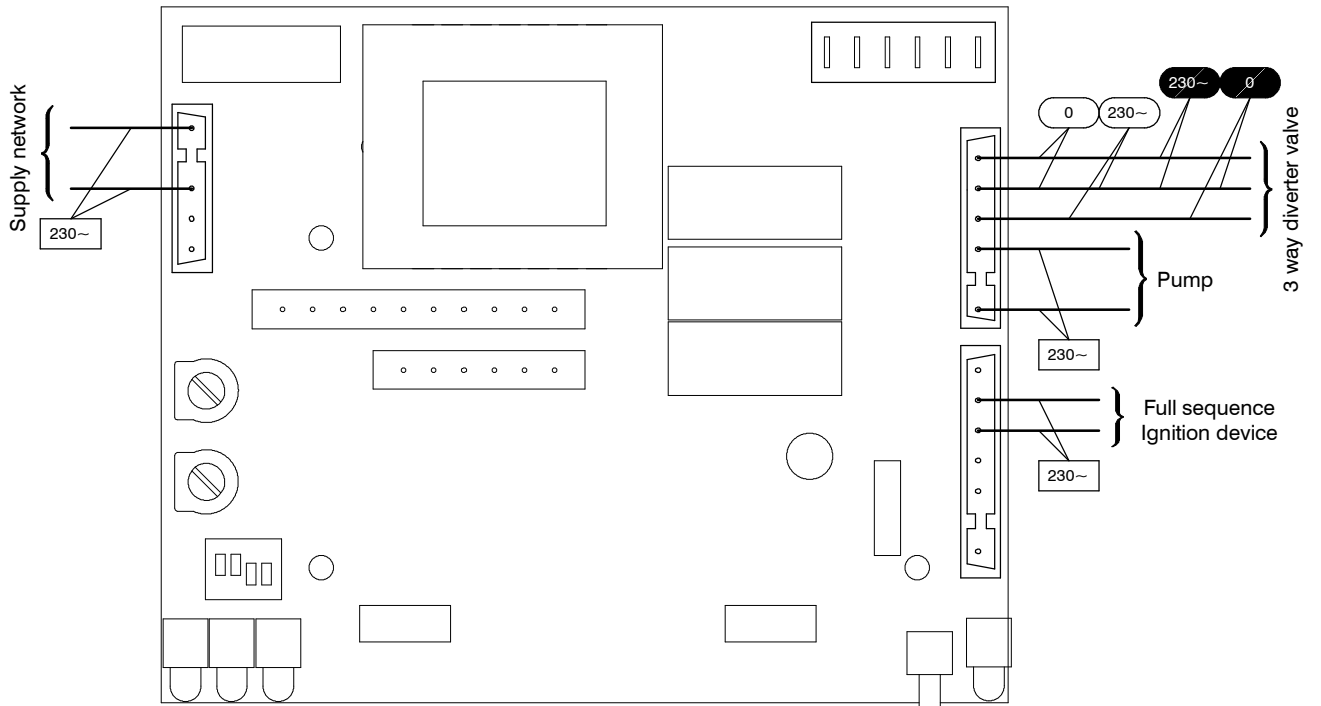

4 Fault finding

Section of the manual → (note ref. in brackets)		Components to check																													
		(1)	(2)	(3)	(4)	6	7.2	8.2	9.9	10.2	11.4	12.2	14.5	15.2	16	17.2	18.2	19.2	(7)	(8)	I	I									
Lock – out signal lamp red	Defect ↓	Power supply line	Gas supply line	Fue pipes	C.h. circuit	D.h.w. circuit	D.h.w. heat exchanger	Pump	Diverter valve	D.h.w. flow switch	Fuse (regulation p.c.b.)	Regulation p.c.b.	Function selectors (reg. p.c.b.)	Full sequence device	Gas valve (on – off operators)	Gas valve (modulating operator)	Main circuit flow switch	D.h.w. filter	Main circuit temp. probe	D.h.w. temp. probe	By – pass valve	Fan and venturi device	Air pressure switch	Ignition electrode	Detection electrode	Safety thermostat	Injectors	Expansion vessel	Safety valve	Pressure gauge	
		■	■												■	■									■	■		■			
NO		■	■								■			■										■							
OFF		■									■			■																	

		Components to check																											
Section of the manual → (note ref. in brackets)		(1)	(2)	(3)	(4)	6	7.2	8.2	9.9		10.2	11.4	12.2	14.5	15.2	16	17.2		18.2	19.2	(7)	(8)	-						
Defect ↓									Fuse (regulation p.c.b.)	Regulation p.c.b.	Function selectors (reg. p.c.b)	Full sequence device	Gas valve (on-off operators)	Gas valve (modulating operator)	Main circuit flow switch	D.h.w. filter	Main circuit temp. probe	D.h.w. temp. probe	By-pass valve	Fan and venturi device	Air pressure switch	Ignition electrode	Detection electrode	Safety thermostat	Injectors	Expansion vessel	Safety valve	Pressure gauge	
Lock-out signal lamp red																													
	The boiler does not supply d.h.w. (cold water from the tap). Regular operation in c/h mode even during a drawing off d.h.w.							■	■	■																			
	On c/h mode the temperature of the main circuit reaches 75°C and the c/h system does not heat. The boiler operates correctly on d.h.w. mode.						■	■																					
	Incorrect modulation									■										■									
	Noisy boiler																												
	The boiler operates correctly but the gas pressure to the burner remains at minimum.									■																			
	Poor d.h.w. temperature																												
Off	Low d.h.w. flow rate																												
	Water leaks from the safety valve during operation on c/h																												■
	Water leaks from the safety valve when the boiler is off.																												■

Note

Useful information can be obtained also from the optical indication given by the appliance operation lights (see section 9.4).

- 1 Check for 230V~ between line (L) and neutral (N)
Verify the integrity of supply cable, plug and external fuses.
Check the polarity of line and neutral connection
- 2 Verify the soundness of the gas supply pipe, the position of stop valves.

3 Check the gas pressure at the inlet test point of the gas valve (see sect. 11.3) with the boiler at rest and during operation and compare it with the values given on the installation booklet.

4 Check for soundness and absence of obstructions. Verify that the flue terminal is correctly installed (see clearances) and ensure that exhaust gas is not sucked back by the boiler.

5 Check for soundness of the circuit and verify its correct filling (see also installation manual).

6 Check the gas pressure at the inlet test point of the gas valve (see sect. 11.3) and compare it with the value given on the installation booklet.

7 Verify the cleanliness of injectors.

8 Check the pressurization of the expansion vessel. Refer to the installation manual for proper values.

9 d.h.w. pressure too high or flow rate too high. If necessary insert a flow rate limiter (14.6).

A jammed by-pass could cause the over-heating of the main circuit and the intervention of the safety thermostat.

Check the **minimum** gas pressure at the outlet test point of the gas valve (see sect. 11.3) and compare it with the value given on the installation booklet.

Verify the cleanliness of injectors.

Check the pressurization of the expansion vessel. Refer to the installation manual for proper values.

d.h.w. pressure too high or flow rate too high. If necessary insert a flow rate limiter (14.6).

5 Primary heat exchanger

5.1 Characteristics

The primary heat exchanger *A* in Fig. 9 has the function of transferring heat produced from combustion of the gas to the water circulating in it.

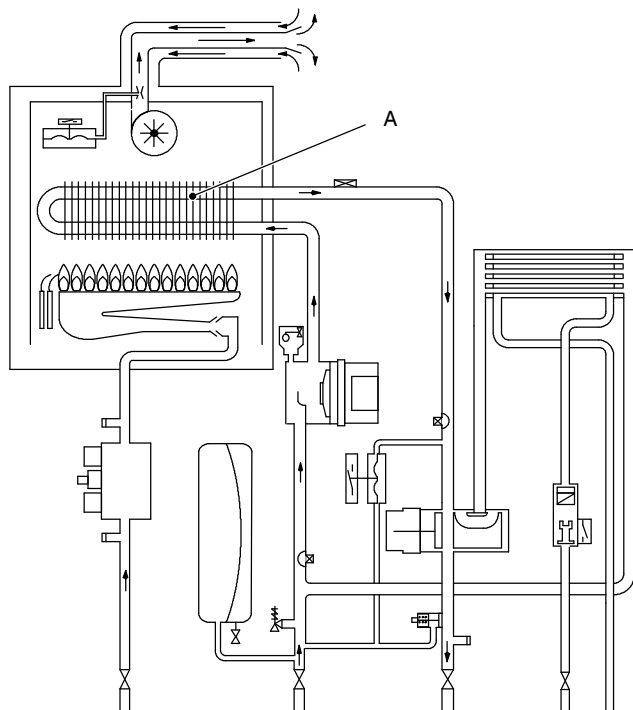

Fig. 9

The hydraulic circuit is composed of 8 elliptical pipes connected in parallel (Fig. 10).

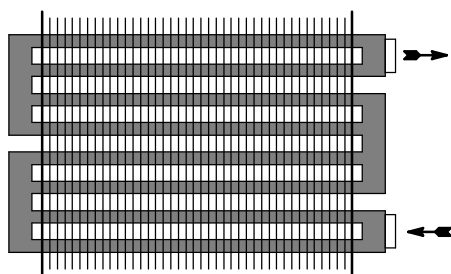

Fig. 10

5.2 Removal

Warning: isolate the boiler from the mains electricity supply before removing any covering or component.

- 1 Empty the primary circuit of the boiler.
- 2 Remove the case panels and the sealed chamber lid (see section 2).
- 3 Remove the combustion chamber lid *B* by unscrewing the screws *C* (Fig. 11).
- 3b For model M90D.28S and M90D.28SR only, remove the screw *D* and the plate *E*.
- 4 Remove the clips *F* and the safety thermostat *G*. It is not necessary to disconnect it from the wiring.

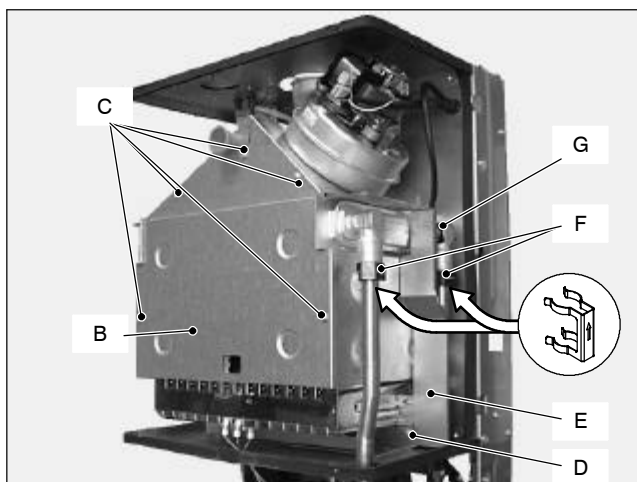

Fig. 11

- 5 Unscrew the connection *H* (Fig. 12), lift the pipe *I* and rotate it right then move it downwards freeing it from the heat exchanger connection.
- 6 Remove the motor of the three way diverter valve (see section 8.3).
- 7 Completely unscrew the connection *J* and rotate the pipe *K* downwards freeing it from the heat exchanger connection.
- 8 Remove the heat exchanger by sliding it forwards.
- 9 Reassemble the boiler carrying out the removal operations in reverse order. **Fit the clips *F* with the arrow pointing upwards as illustrated in Fig. 11.**



Fig. 12

5.3 Cleaning

If there are deposits of soot or dirt between the blades of the heat exchanger, clean with a brush or non-metallic bristle brush.

In any case, avoid any actions that can damage the protective varnish with which the exchanger has been covered.



Warning: After cleaning or replacement as detailed above refer to section **Combustion analysis check** in the chapter **Maintenance of the installation instructions manual.**

6 D.h.w. heat exchanger

6.1 Function

The d.h.w. heat exchanger *A* in Fig. 13 allows the instantaneous transfer of heat from the primary hydraulic circuit to the water destined for d.h.w. use.

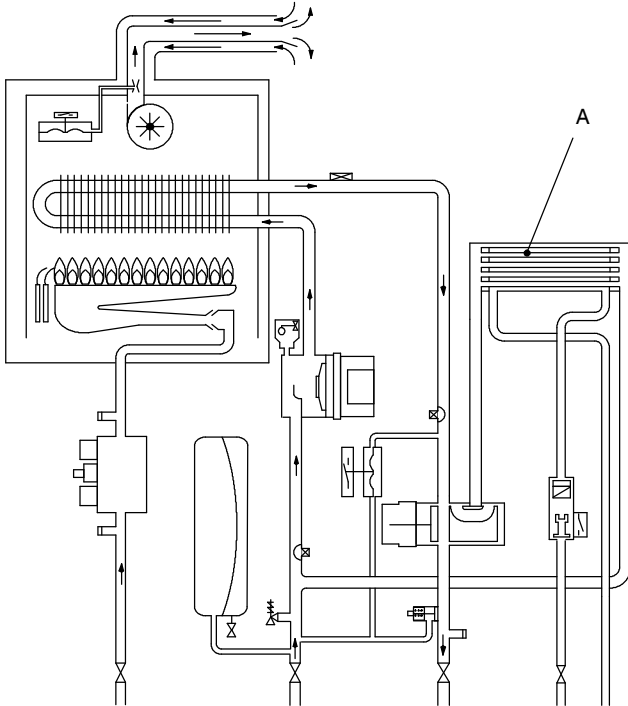
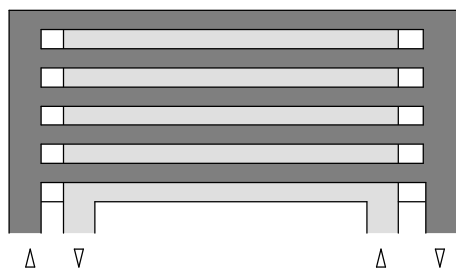

Fig. 13

The schematic structure is shown in Fig. 14.



- Primary hydraulic circuit
- Domestic hot water circuit

Fig. 14

6.2 Removal

Warning: isolate the boiler from the mains electricity supply before removing any covering or component.

- 1 Remove the front and right hand side panels of the case.
- 2 Empty the primary circuit and the d.h.w. circuit of the boiler.
- 3 Remove the motor of the three way diverter valve (see section 8.3).
- 4 Completely unscrew the two Allen key screws *B* (Fig. 15) which hold the exchanger to the brass groups.

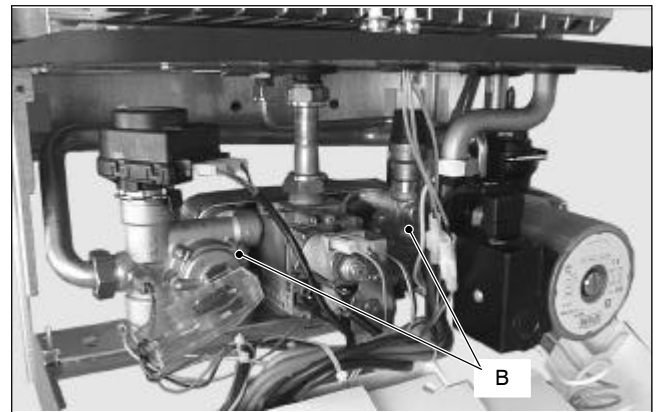

Fig. 15

- 5 Move the exchanger towards the rear of the boiler and extract it.

Reassemble the d.h.w. heat exchanger carrying out the removal operations in the reverse order.

Attention. When reassembling the exchanger be sure to put the off center location/securing pin indicated in Fig. 16 towards the left side of the boiler.

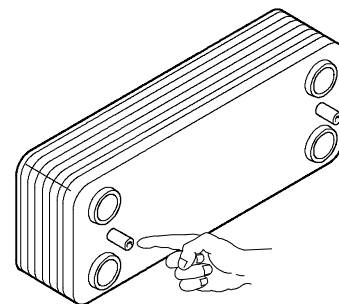

Fig. 16

7 Pump

7.1 Function

The pump A in Fig. 17 has the function of making the water in the main circuit circulate through the main heat exchanger and therefore through the c.h. system (during the c.h. function) or through the secondary heat exchanger (during the d.h.w. function).

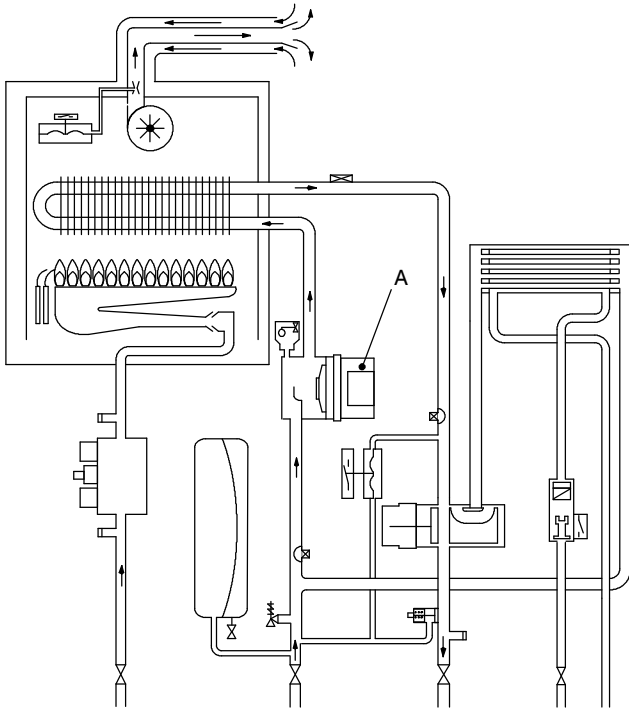

Fig. 17

7.2 Checks

Warning: isolate the boiler from the mains electricity supply before removing any covering or component.

Check that the pump is not seized and that the movement of the rotor is not subject to mechanical impediments.

With the boiler off, remove the front panel. Remove the air release plug of the pump and turn the rotor with a screwdriver.

Check the electrical continuity.

With the boiler off, remove the front panel and disconnect the connector B (Fig. 18).

Measure the electrical resistance between the pump supply connections.

Electrical resistance of the windings (at ambient temperature) must be about 230 Ω

Check the absence of starting defects.

With the boiler off remove the front case panel.

Remove the air release plug from the pump. Start the boiler and with a screwdriver, turn the rotor in the direction of the arrow. If there is a defect in starting, the rotor will begin to turn normally only starting it manually.

Check that the impeller is integral with the rotor. With the boiler off remove the front and right hand side case panels, lower the control panel and empty the primary circuit.

Remove the pump head by undoing the screws which hold it to the pump body and check that the impeller is firmly joined to the rotor.

7.3 Removal

Warning: isolate the boiler from the mains electricity supply before removing any covering or component.

- 1 Remove the front and right hand side case panels
- 2 Empty the primary circuit of the boiler.
- 3 Extract and lower the control panel.
- 4 Disconnect the connector B (Fig. 18).
- 5 Unscrew the connection C and move the pipe upwards freeing it from the outlet port of the pump.
- 6 Remove the fork D and the capillary pipe .
- 7 Remove the locking plate E right (Fig. 18).

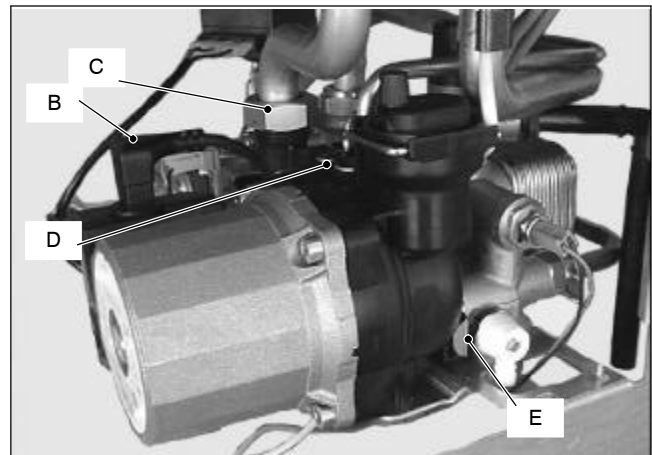

Fig. 18

- 8 Loosen the connection F, remove the fork G and the pipe H.

- 9 Unscrew the two screws I that hold the pump on the frame (Fig. 19) and remove the pump towards the front of the boiler.

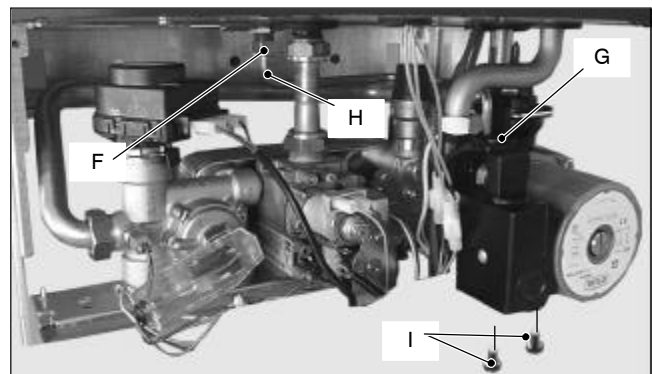

Fig. 19

Reassemble the pump carrying out the removal operations in the reverse order. When reassembling the pump, check the correct location of the O-ring gasket in the inlet port of the pump that seals the connection between the pump and the brass group .

8 Three way diverter valve

8.1 Function

The diverter valve A (Fig. 20) has the function of modifying the hydraulic circuit of the boiler by means of an electric command given by the electronic control p.c.b. in order to send the water that exits the primary heat exchanger towards the c.h. system or towards the d.h.w. heat exchanger.

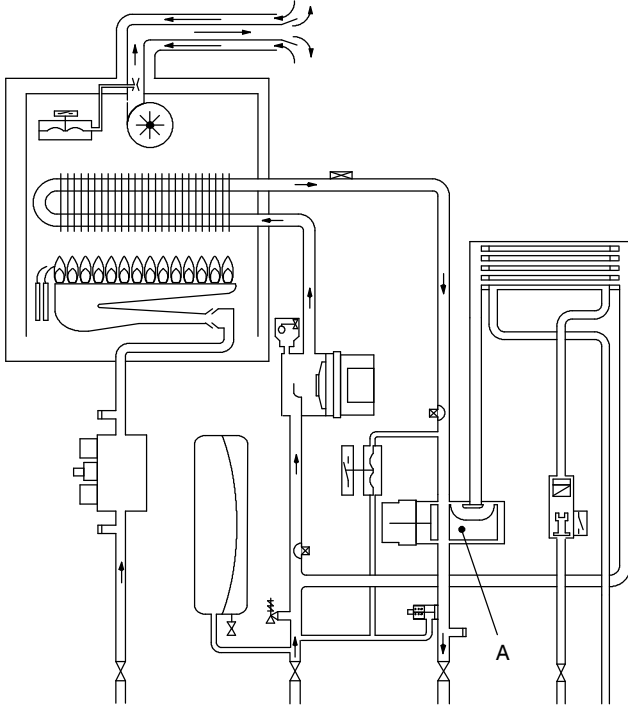

Fig. 20

8.2 Checks

✓ Check the electrical continuity

Fig. 21 indicates the relationship between the electric command coming from the electronic control p.c.b. and the position of the actuator B (brass spindle) when the boiler operates in **d.h.w. mode**.

Fig. 22 indicates the relationship between the electric command coming from the electronic control p.c.b. and the position of the actuator B (brass spindle) when the boiler operates in **c.h. mode**.

In both figures the relationship between the position of the actuator and the resistance of the motor windings (the motor must be disconnected from the wiring) is also given.

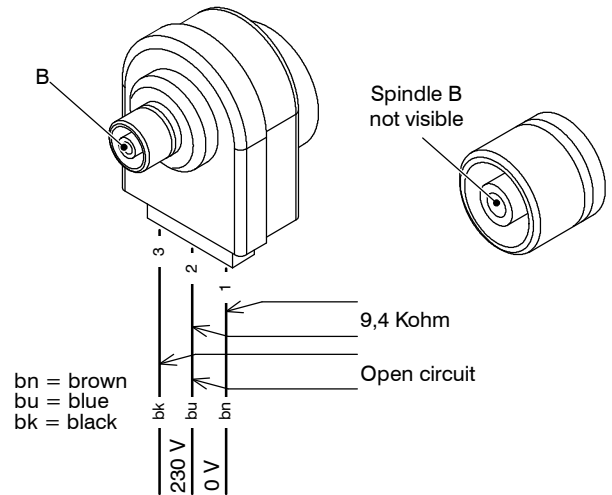

Fig. 21 – D.h.w. mode

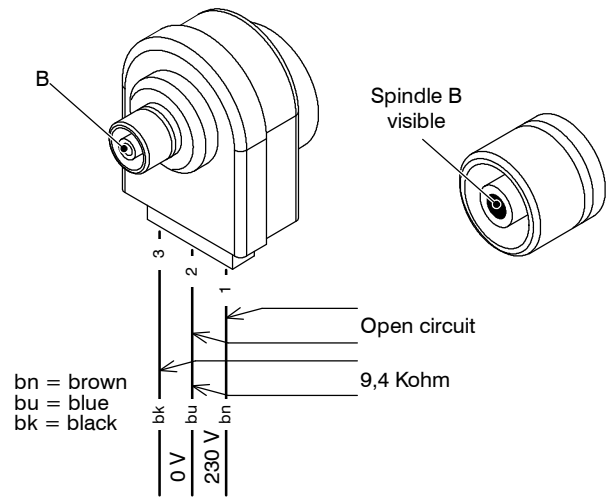

Fig. 22 – C.h. mode

8.3 Removal of the electric actuator

⚡ **Warning: isolate the boiler from the mains electricity supply before removing any covering or component.**

- 1 Remove the front case panel.
- 2 Disconnect the connectors C (Fig. 23).
- 3 Remove the fixing spring D and remove the actuator E.
Reassemble the actuator carrying out the removal operations in the reverse order.
When reassembling the actuator, refer to Fig. 21 or to the wiring diagram in section 3.1 for the correct wiring connection.

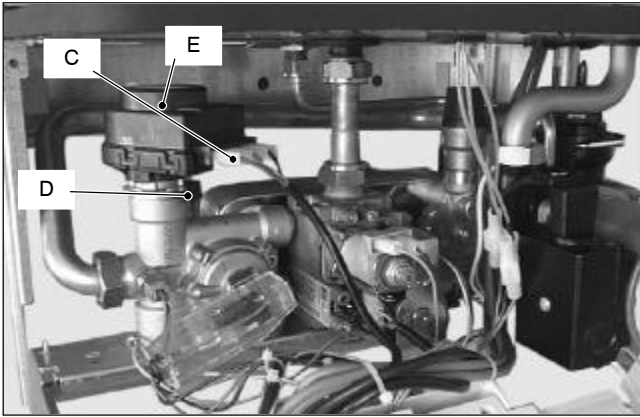

Fig. 23

8.4 Removal of the diverter group and its internal parts

- 1 Remove the front and both side case panels.
- 2 Empty the primary circuit and the d.h.w circuit of the boiler.
- 3 Remove the electric actuator (see section 8.3).
- 4 Remove the fixing spring *F* (Fig. 24) and remove the primary circuit flow switch *G*.
- 5 Disconnect the c.h. temperature probe *H*.
- 6 Unscrew the connector *I*, the c.h. flow connector and the d.h.w. outlet connector.

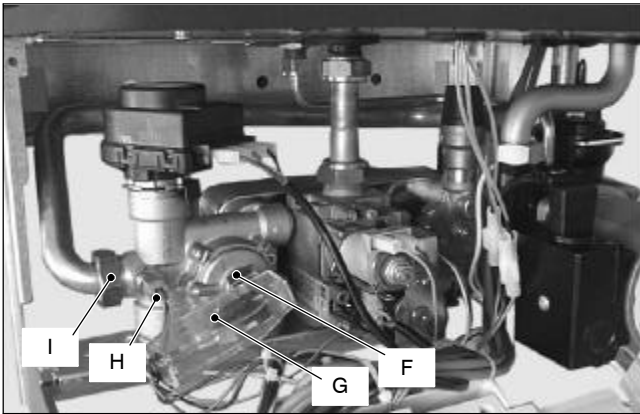

Fig. 24

- 7 Remove the d.h.w. heat exchanger (see section 6.2).
- 8 Remove the fork *J* and move away the pipe *K* (Fig. 25).

- 9 Unscrew the screw *L* and remove the diverter group.

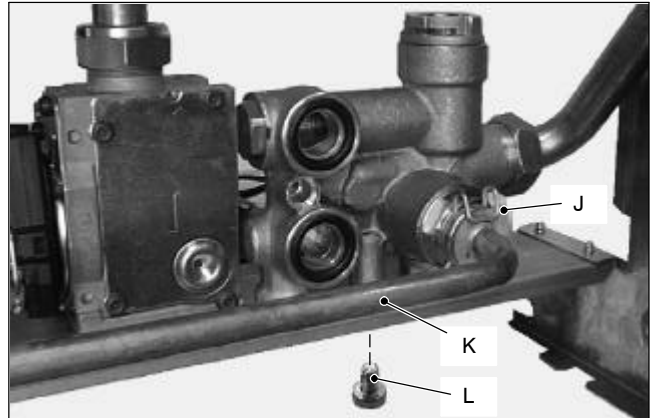

Fig. 25 Rear view of the boiler

- 10 Refer to the exploded view in Fig. 26 to remove the internal parts of the three way diverter valve.



Fig. 26

- 11 Reassemble the diverter group carrying out the removal operations in the reverse order.

9 Electronic control p.c.b.

9.1 Function

Inlet Information

On the Electronic control p.c.b.....

Function control*
 C.h. temperature adjustment*
 D.h.w. temperature adjustment*
 Function dip-switches
 Max. c.h. gas pressure adjustment
 Ignition gas pressure adjustment
 Boiler reset button*

*control panel fascia

From other boiler devices....

C.h. temperature probe NTC
 D.h.w. temperature probe NTC
 D.h.w. flow switch
 Primary circuit flow switch
 Room thermostat (if fitted)
 Time switch
 Flame presence signal*
 *from the full sequence ignition device

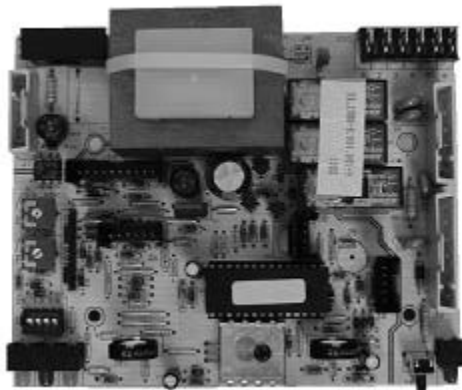

Outlet command

Pump
 Three way diverter valve
 Full sequence ignition device
 Modulation operator
 Appliance operation lights*
 Lock-out signal lamp*
 *control panel fascia

The fundamental function of the Electronic control p.c.b. is that of controlling the boiler in relation to the external needs (i.e. heating the dwelling or heating the water for d.h.w. use) and operating in order to keep the temperature of the hydraulic circuits constant.

This is obviously possible within the useful power and maximum working temperature limits foreseen.

Generally, the Electronic control p.c.b. receives inlet information coming from the boiler (the sensors) or from the outside (knobs, room thermostat, etc.), processes it and consequently acts with outlet commands on other components of the boiler (Fig. 27).

9.2 Selection and adjustment devices

On the Electronic control p.c.b. several selection, adjustment and protection devices are located. (Fig. 28).

Some of these devices are directly accessible by the user (function control, temperature adjustment potentiometers etc.) others are accessible by removing the service panel or the control panel lid.

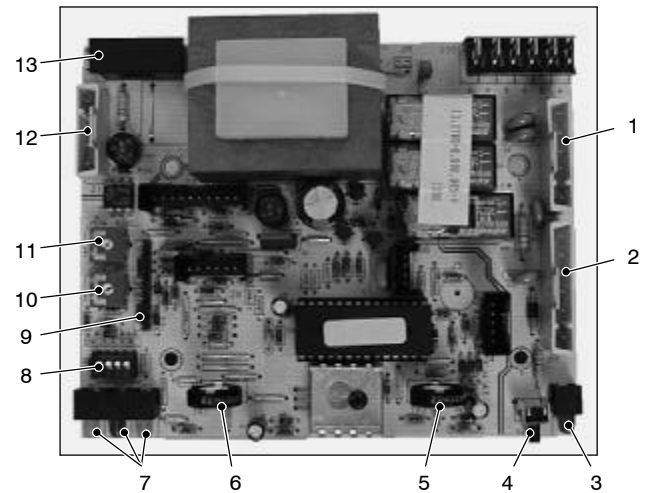

Fig. 28

- 1 J3 connector
- 2 J2 connector
- 3 Lock-out signal lamp
- 4 Boiler reset button
- 5 Function control / C.h. temperature adjustment
- 6 D.h.w. temperature adjustment
- 7 Appliance operation lights
- 8 Dip-switch selectors
- 9 Setting jumpers
- 10 Ignition gas pressure adjustment (ACC.)
- 11 Maximum c.h. gas pressure adjustment (RISC.)
- 12 J1 connector
- 13 Fuse 1,6 A T

9.3 Checking the temperature

The Electronic control p.c.b. makes it possible to separately adjust the c.h. water flow temperature and d.h.w. outlet temperature.

The temperature of the water is converted into an electric signal by means of temperature probes.

The user, setting the desired temperature with the con-

control panel knobs operates the variable elements (5 and 6 in Fig. 28) of the electronic control p.c.b.

If the power requested is lower than 40% of the maximum power output then control is achieved by switching ON the burner at minimum power, then switching OFF (ON/OFF function). If the power requested is higher, then the burner is switched ON at maximum power and will control by modulating to 40% of the maximum power output.

During the c.h. operation (Fig. 29), the signal coming from the c.h. temperature probe is compared to the signal given by the control panel through the adjustment made by the user (knob ). The result of such a comparison operates the modulation of the gas valve, consequently changing the useful output of the boiler.

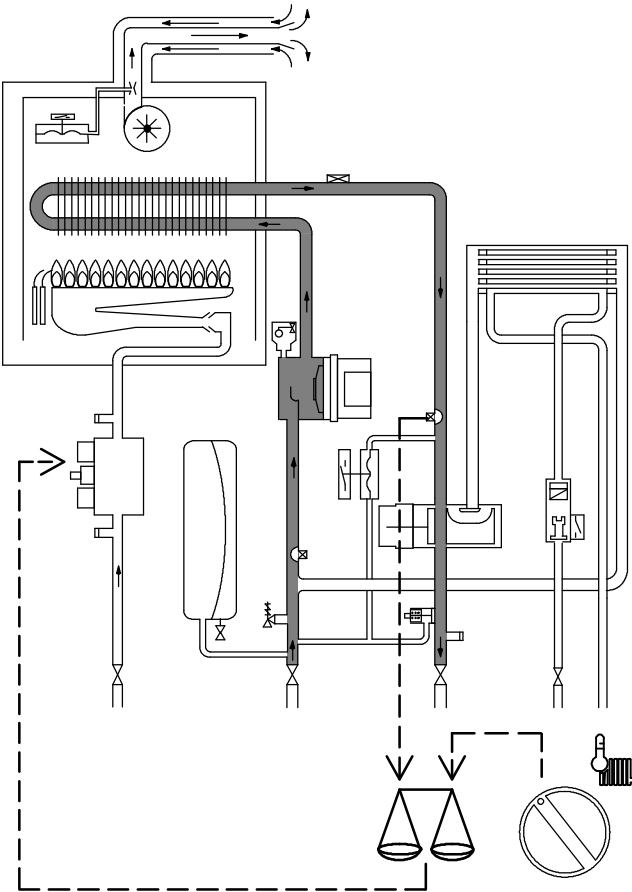



Fig. 29

When the boiler functions in d.h.w. (Fig. 30), the signal coming from the d.h.w. temperature probe is compared with the signal given by the control panel through the adjustment made by the user (knob ).

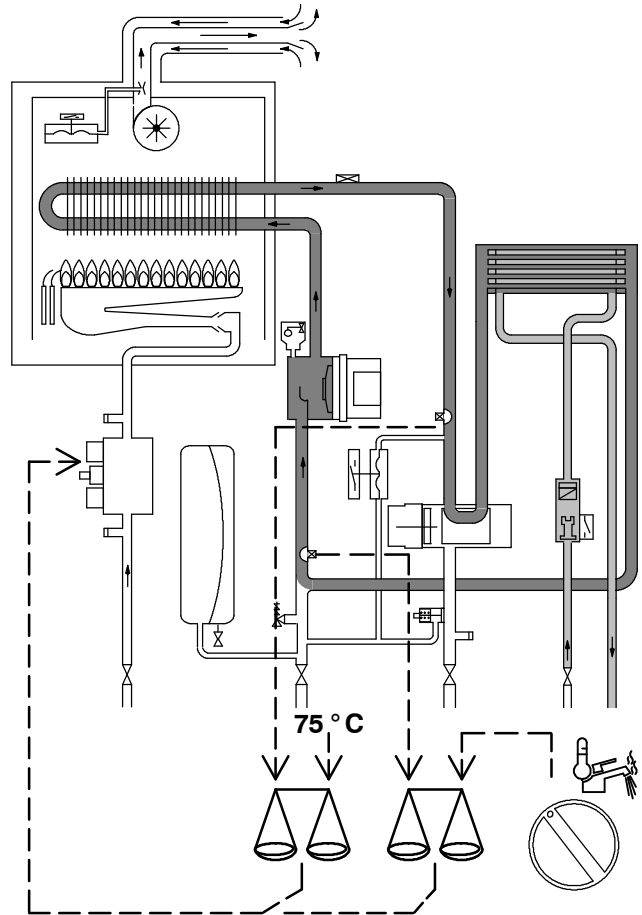



Fig. 30

Normally, the result of the comparison between these two signals directly operates the adjustment elements of the gas valve modulation device, adjusting the useful output generated in order to stabilize the temperature of the exiting water.

If during the d.h.w. mode operation, the temperature of the primary circuit goes over 75°C, the useful output is automatically reduced so that the primary circuit cannot reach excessive temperatures.

The control sequences in  function and in  function are illustrated in detail in sections 9.11 and 9.12.

9.4 Operation lights

The Electronic control p.c.b. is provided with three lamps (L.E.D. indicators) 7 in Fig. 28 that give optical information during the operation of the boiler.

The green lamp on the left gives information whether the boiler is in stand-by mode or during the normal operation of the boiler.

The following table gives the relationship between the lamp indication and its meaning.

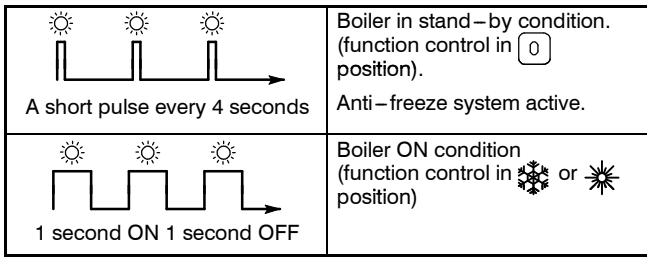

With the boiler switched ON (★ or ❄️) all the lamps (7 in Fig. 28) are activated.

The following table gives the relationship between each of the possible lamp combinations and their meaning.

	<input type="radio"/>	<input type="radio"/>	Normally operating boiler (see the previous table for details)
	<input type="radio"/>		C.h. operation
	<input type="radio"/>		D.h.w. operation
		<input type="radio"/>	Frost protect operation
<input type="radio"/>	<input type="radio"/>		D.h.w. operation Excessive temperature on primary circuit
<input type="radio"/>			Faulty c.h. temperature probe NTC
<input type="radio"/>		<input checked="" type="radio"/>	Faulty d.h.w temperature probe NTC
	<input checked="" type="radio"/>	<input type="radio"/>	Faulty primary circuit (no water or absence of flow)
	<input checked="" type="radio"/>		Lack of burner ignition (no ignition signal from the full sequence ignition device)
<input checked="" type="radio"/>		<input type="radio"/>	Ignition gas pressure adjustment
	<input checked="" type="radio"/>	<input checked="" type="radio"/>	Minimum gas pressure adjustment
<input type="radio"/>	<input type="radio"/>	<input type="radio"/>	Lack of power supply or faulty electronic control p.c.b. *
<input checked="" type="radio"/>	<input checked="" type="radio"/>	<input checked="" type="radio"/>	Faulty electronic control p.c.b. *
<input type="radio"/>	<input checked="" type="radio"/>		
Lamp OFF	Lamp ON	Flashing lamp, alone or simultaneously with another lamp.	Flashing lamp, alternate with another lamp.
* These conditions are normal only for a short time when the power supply is applied to the boiler. If permanent they indicate a faulty p.c.b.			

9.5 Dip-switch selectors

The function selectors 8 (Fig. 28 and Fig. 31) are micro-switches with which it is possible to select the various boiler control function modes.

In Fig. 31 the selectors are illustrated in the configuration in which the boiler is set in the factory (natural gas boiler).

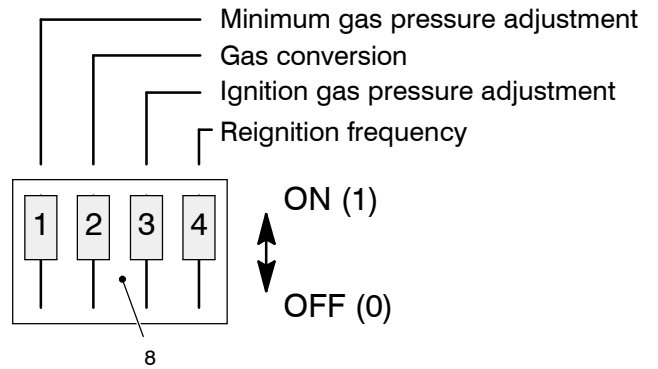

Fig. 31

○ Selector 1

This forces the boiler to operate at the minimum gas pressure in order to allow the adjustment of the minimum gas pressure at the burner (on the modulation operator of the gas valve).

After any adjustment operation the selector has to be brought back to the normal position (ON).

○ Selector 2

This selects the boiler functions on the basis of the type of gas used.

It allows the selection of the maximum supply current given to the modulator device.

To set selector 2 correctly follow the table in Fig. 32.

Gas supply	Position of selector	Approx. Max current through the modulator device
Natural gas	On	120 mA
L.P.G.	Off	165 mA

Fig. 32

○ Selector 3

This forces the functioning of the boiler in order to allow the optimal gas pressure at the burner to be adjusted during the ignition phase.

The adjustment (see section 9.7) is done by means of the potentiometer "10" marked "ACC" (Fig. 28 on page 19).

After the adjustment operations bring the selector back to the normal position (ON).

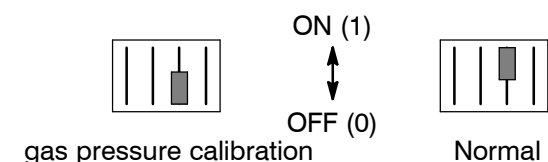

Fig. 33

○ Selector 4

This allows you to select the minimum time that must pass between two ignitions of the burner in c.h. function.

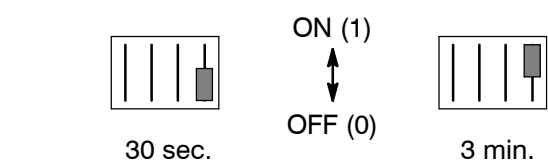

Fig. 34

9.6 Setting jumpers

Two setting jumpers are fitted on the Electronic control p.c.b.

Refer to Fig. 35 for the position of the jumpers when the Electronic control p.c.b. is fitted on a M90D.24S or M90D.28S boiler.

Refer to Fig. 36 when the Electronic control p.c.b. is fitted on a M90D.24SR or M90D.28SR boiler.

The numbers refer to the marking printed on the circuit board.

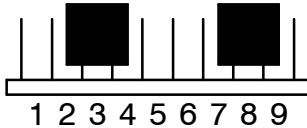

Fig. 35

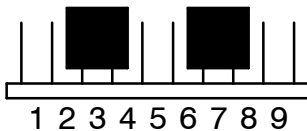

Fig. 36

9.7 Ignition gas pressure adjustment

By using the device "10" (Fig. 28) marked "ACC." on the Electronic control p.c.b., it is possible to adjust the gas pressure at the injectors in the ignition phase.

This pressure is maintained at the injectors until ignition occurs (ionization signal from the full sequence ignition device).

To carry out the adjustment move the function selector 3 to the OFF position (Fig. 33) and use the adjustment device "10" (ACC).

Adjust the gas pressure at the injectors to the value indicated in the tables of the User/Installation manual (*Technical information* section, *Gas pressures at the burner* table).

By rotating the device clockwise the pressure increases.

Check the regular ignition of the burner by turning the boiler on and off repeatedly.

After the adjustment operations bring the selector 3 back to the normal position (ON).

9.8 Max c.h. power adjustment

By using device 11 (Fig. 28) marked "RISC." on the Electronic control p.c.b., you can limit the maximum useful output delivered during the c.h. operating mode. This adjustment does not influence the maximum useful output delivered during the d.h.w. operating mode.

By rotating the device clockwise the pressure increases.

9.9 Checks

✓ Check that the fuse is complete

If the Electronic control p.c.b. does not supply any device (pump, fan, etc.) check that the fuse 13 (Fig. 28) is complete.

If the fuse has blown replace it with one that has the same characteristics after having identified the reason for failure.

✓ Check the setting jumpers position

Two setting jumpers must be fitted on the Electronic control p.c.b. as shown in Fig. 35 and Fig. 36.

9.10 Removal of the electronic control p.c.b

⚡ **Warning: isolate the boiler from the mains electricity supply before removing any covering or component.**

- 1 Gain access to the parts located inside the control panel as explained in the section 2.3 of this manual.
- 2 Remove all the wiring connected to the Electronic control p.c.b.
To disconnect the connectors J1, J2 and J3 (12, 2 and 1 in Fig. 28) delicately flex the hook present on one side of each socket.
- 3 Remove the spindles of the c.h. and d.h.w. temperature adjustment knobs by delicately pulling them with pliers in the direction shown by the arrow in Fig. 37.

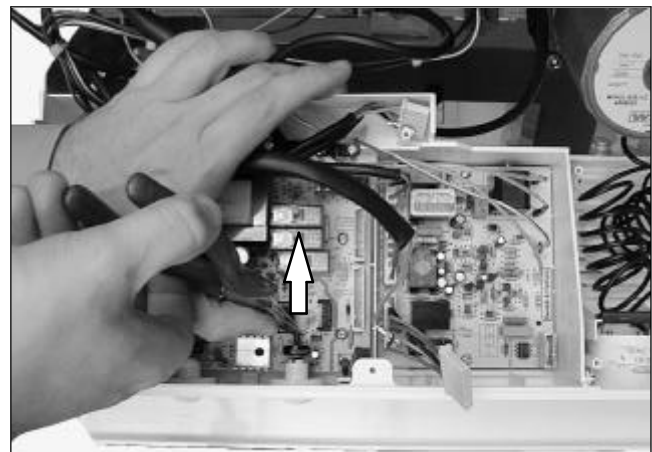

Fig. 37

- 4 Unscrew the four screws that hold the Electronic control p.c.b. on to the control panel.
- 5 Remove it by lifting its rear edge and freeing it from any of the wiring.
- 6 Re-assemble the Electronic control p.c.b. following the removal procedures in the reverse order.

Important

When re-assembling the Electronic control p.c.b.:

- 7 Fit the p.c.b. into the control panel by first inserting the front lower edge under the control knob shafts. Lower the rear edge and ensure that no wiring is trapped beneath.
- 8 Insert the spindles in the control panel knobs until the notch A (Fig. 38) reaches the potentiometer edge. It is not necessary to force them in the knob.
- 9 While tightening the screws that fix the Electronic control p.c.b. on the control panel, keep the

p.c.b. towards the control panel fascia making sure of the contact between the boiler reset button *B* and the tab *C* (Fig. 38).

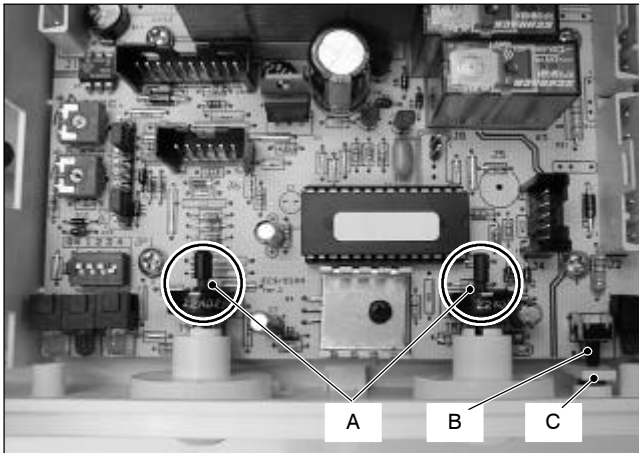

Fig. 38

Attention

After installing the Electronic control p.c.b. :

- 10 Make sure the c.h. (🔥) and d.h.w. (🚿) temperature adjustment knobs can move freely for the complete range.
If not, remove the spindle again as described at step 3, turn the knob half a turn and re-insert the spindle.
- 11 Operate the boiler and close the gas inlet cock so that the boiler goes into the safety lock-out state. Verify the correct operation of the boiler reset button by pressing and releasing it.



Warning: After cleaning or replacement as detailed above refer to section *Combustion analysis check* in the chapter *Maintenance of the installation instructions manual*.

9.11 Thermal control in the "❄️" mode

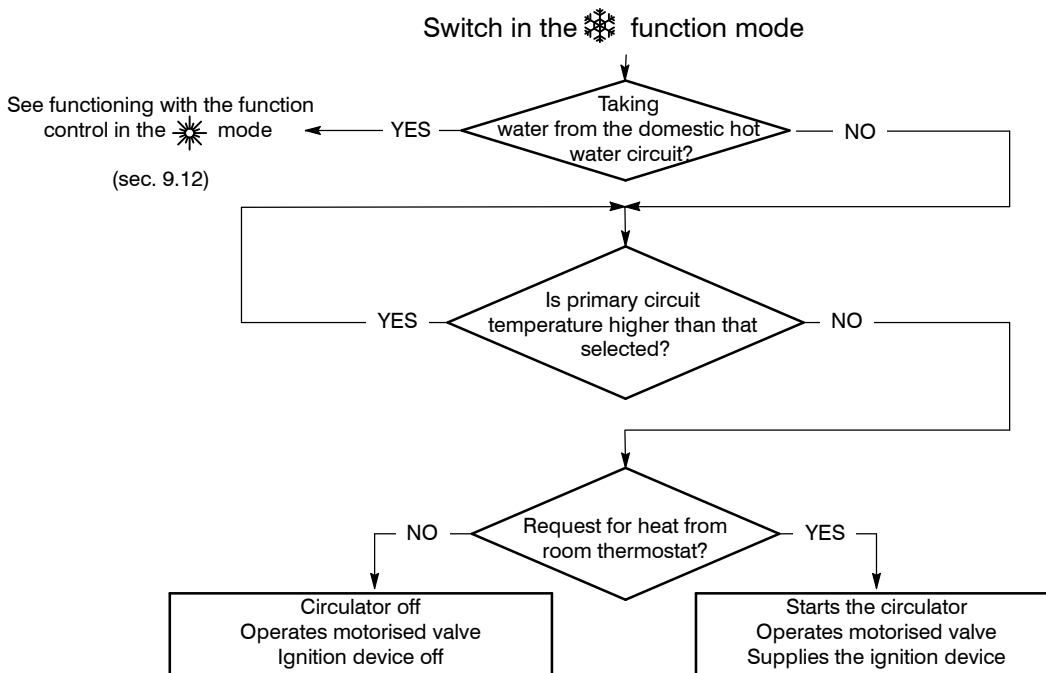

Fig. 39

9.12 Thermal control in the "☀️" mode

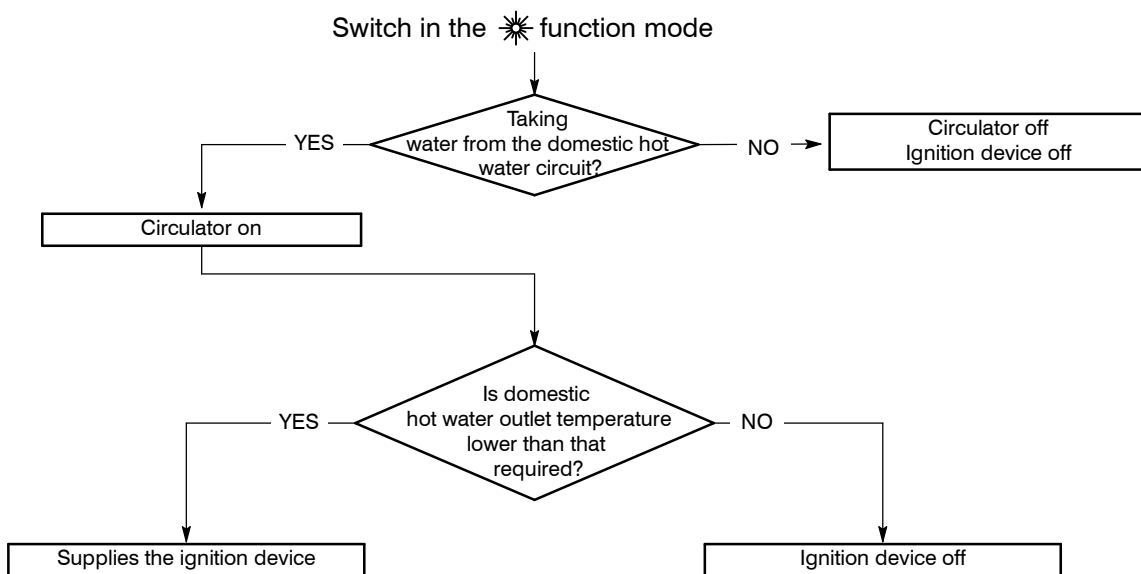

Fig. 40

10 Full sequence ignition device

10.1 Function

The Full sequence ignition device used on the boiler carries out the following fundamental functions:

- does a sequence of operations (ignition cycle) which lead to the ignition of the gas at the burner
- checks the presence of the flame during the entire period in which it is activated
- supplies the fan and checks its functioning by means of the signal coming from the air pressure switch.

The Full sequence ignition device is supplied by the electronic control p.c.b. when the ignition of the burner is requested.

The Full sequence ignition device has a **safety function** and any incorrect interventions or tampering can result in conditions of dangerous functioning of the boiler.

The Full sequence ignition device can lock the functioning of the boiler (lock state) and stop its functioning up to the resetting intervention. The lock is signalled by the lighting of the lock – out signal lamp and the device can be reset only by using the boiler reset button placed on the control panel fascia.

Some components which are connected to the device can activate the lock state. The causes of a lock state could be:

- The intervention of the safety thermostat (overheat of the primary circuit).
- A fault on gas supply
- Faulty ignition (faulty ignition electrodes, their wiring or connection).
- Faulty flame detection (faulty detection electrode, its wiring or connection).
- Gas injectors blocked
- Faulty modulation gas valve (faulty on – off operators or not electrically supplied).
- Faulty Full sequence ignition device.

Other components like the air pressure switch can temporarily stop the ignition of the burner but allow its ignition when the cause of the intervention has stopped.

Fig. 42 shows the sequence of the operations that are carried out at the start of every ignition cycle and during normal functioning.

10.2 Checks

- ✓ Lock sequence

Start the boiler until the burner is ignited.

With the burner firing, interrupt the gas supply. The Full sequence ignition device must carry out a complete ignition cycle and then stop.

By turning the boiler on and off by means of the function switch the device must not unlock and the burner must not turn on.

- ✓ Fan functioning device

With the boiler operating and the burner on, open the negative pressure test point of the Venturi device. At the moment of opening the burner must turn off.

10.3 Removal

⚡ **Warning: isolate the boiler from the mains electricity supply before removing any covering or component.**

- 1 Gain access to the parts located inside the control panel as explained in the section 2.3 of this manual.
- 2 Remove all the wiring connected to the Full sequence ignition device.
To disconnect the connectors *A*, delicately flex the hook present on one side of each socket (Fig. 41).
- 3 Unscrew the two screws *B* that hold the Full sequence ignition device on the panel and remove the component.

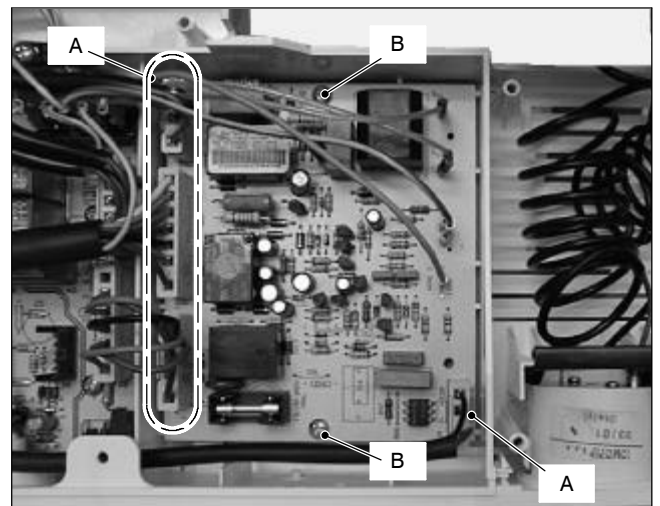

Fig. 41

- 4 Re-assemble the Full sequence ignition device following the removal procedures in the reverse order.

10.4 Ignition and control sequence

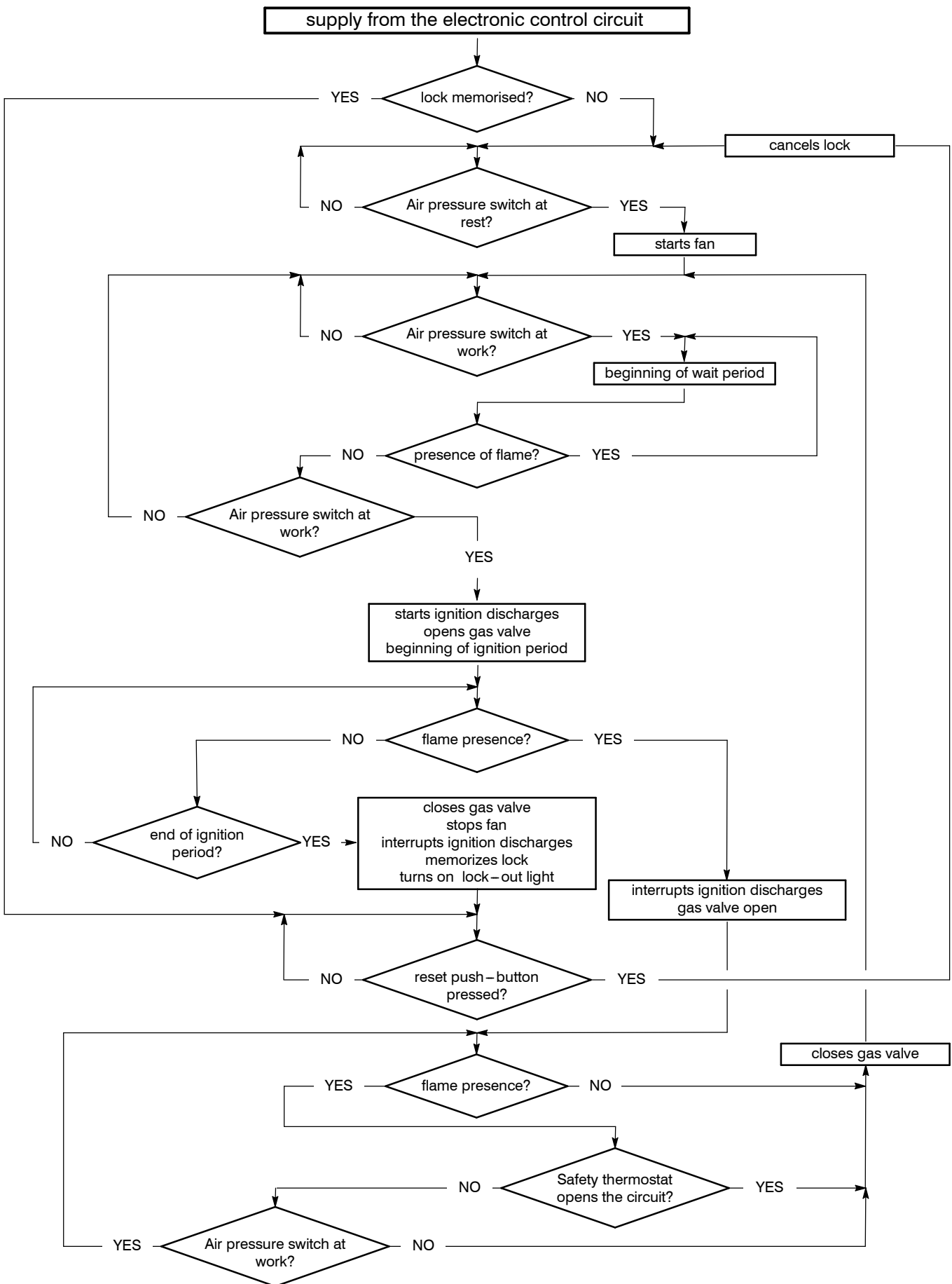

Fig. 42

11 Modulating gas valve

11.1 Function

The Modulating gas valve A in Fig. 43 controls the gas inflow to the boiler burner.

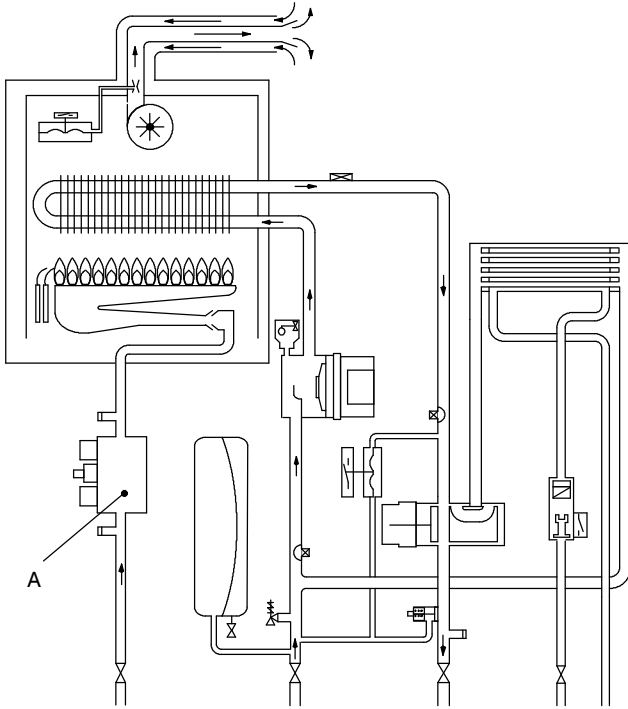

Fig. 43

By means of an electric command given to the on–off operators the passage of the gas through the Modulating gas valve can be opened or closed.

By means of an electric command given to the modulation operator the pressure can be varied and therefore the gas flow rate to the burner (modulation). The modulation operator has mechanical components which allow the adjustment of the minimum and maximum pressure exiting the valve.

11.2 Nomenclature of the parts (Fig. 44)

- 1 Modulation operator's electric connectors
- 2 Minimum gas pressure adjustment
- 3 On–off operators
- 4 Maximum gas pressure adjustment
- 5 On–off operators electric connector
- 6 Gas valve inlet pressure test point
- 7 Modulation operator
- 8 Gas valve outlet pressure test point

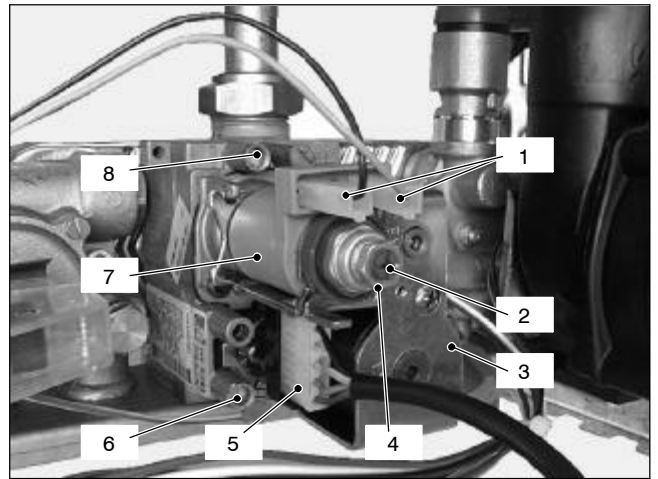

Fig. 44

11.3 Adjustment

Warning: isolate the boiler from the mains electricity supply before removing any covering or component.

- 1 Remove the front panel of the case.
- 2 Open the gas valve inlet pressure test point (6 in Fig. 44) at the valve input, connect a suitable pressure gauge and check the gas pressure of the supply network.
- 3 Remove the gauge and close the pressure test point 6.
- 4 Open the gas valve outlet pressure test point (8 in Fig. 44) and connect the gauge;
- 5 Remove the protection cap from the mechanical pressure adjustment components;
- 6 Start the boiler at its maximum power. Operate the boiler in d.h.w. mode or ensure that the boiler is not range rated if the test is carried out in c.h. mode.
- 7 Rotate the maximum gas pressure adjustment (4 in Fig. 44) until you obtain the required pressure (by rotating clockwise the pressure increases).
- 8 Disconnect one of the two connectors (1 in Fig. 44) or, alternatively, remove the service panel as explained in the section 2.3 of this manual and set the dip–switch selector 1 (see section 9.5) to the OFF position.
- 9 Rotate the minimum gas pressure adjustment (2 in Fig. 44) until you obtain the required pressure (by rotating clockwise the pressure increases).
- 10 Turn the boiler off and re–connect the wire to the modulating operator (or set the dip–switch selector 1 back to the ON position).
- 11 Start the boiler and check again the maximum gas pressure setting.
- 12 Turn the boiler off and disconnect the gauge.

Important: after the gas pressure checks and any adjustment operations, all of the test points must be sealed.

11.4 Checks

Warning: isolate the boiler from the mains electricity supply before removing any covering or component.

- ✓ Check the modulation operator coil
 - 1 Remove the front panel of the case.
 - 2 Disconnect the connectors *B* (Fig. 47) from the modulating operator and measure the electrical resistance of the coil. Its electrical resistance value must be approx. 80 Ω*.
- ✓ Check the on–off operators coils
 - 1 Remove the front panel of the case.
 - 2 Disconnect the electrical connector *C* (Fig. 47).
 - 3 Measure the electrical resistance between the connector pins of the on–off operators as illustrated in Fig. 45.

Upper on–off operator
approx. 6 400 Ω*

Lower on–off operator
approx. 920 Ω*

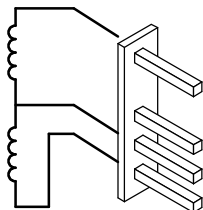

* at ambient temperature.
Fig. 45

11.5 Removal of the on–off operators coils

Warning: isolate the boiler from the mains electricity supply before removing any covering or component.

- 1 Remove the front panel of the case as explained in the section 2.3 of this manual.
- 2 Disconnect the connector *D* (Fig. 46).
- 3 Unscrew the screw *E* and remove on–off operator coils.
- 4 Reassemble the coils carrying out the removal operations in reverse order.

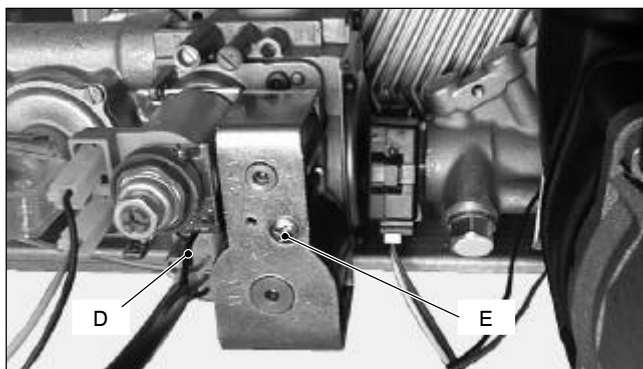

Fig. 46

11.6 Removal of the gas valve

Warning: isolate the boiler from the mains electricity supply before removing any covering or component.

- 1 Remove the front panel of the case as explained in the section 2.3 of this manual.
- 2 Disconnect the connectors *B* and *C* (Fig. 47).
- 3 Turn off the gas supply and disconnect the gas isolation cock connector from the inlet port of the gas valve.
- 4 Unscrew the connectors *F* and remove the pipe *G*.
- 5 Unscrew the screws *H* and remove the valve.
- 6 Reassemble the valve carrying out the removal operations in reverse order.

After any service operation on the components of the gas circuit check all the connections for gas leaks.

Warning: After cleaning or replacement as detailed above refer to section *Combustion analysis check* in the chapter *Maintenance of the installation instructions manual*.

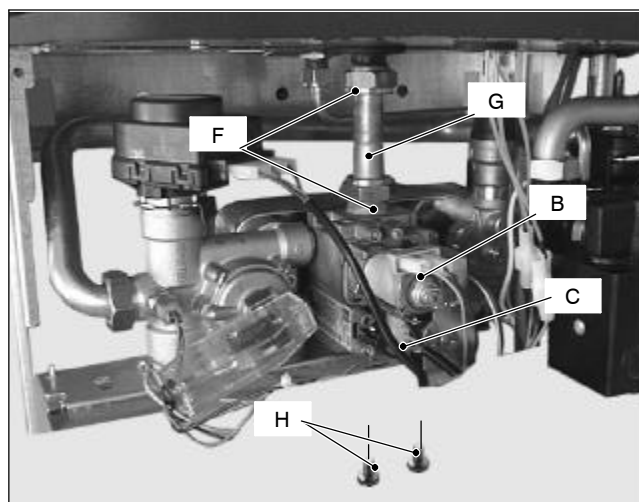

Fig. 47

12 Primary circuit flow switch

12.1 Function

The Primary circuit flow switch (A in Fig. 48) function is to detect water flowrate through the primary hydraulic circuit of the boiler.

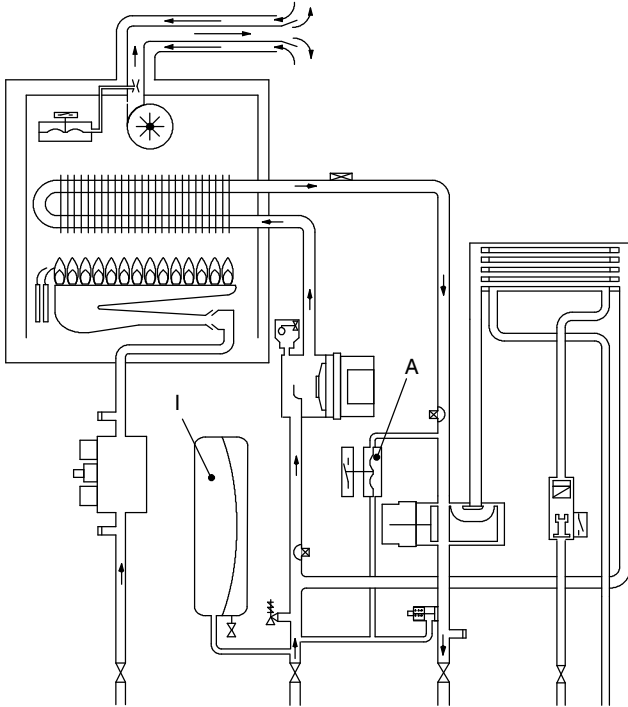

Fig. 48

This hydraulic/membrane operated electrical micro-switch device will control the functioning of the ignition control circuit, providing there is an adequate quantity and flow of water in the primary circuit. Any failure of the pump or obstructions in the primary circuit, whilst in either c.h. or d.h.w. modes, will not allow the device to operate.

This device is connected to the electronic control p.c.b. and if, after the pump operates, it does not activate within 20 seconds the control board will indicate that a fault condition (see section 9.4 of this manual) has occurred.

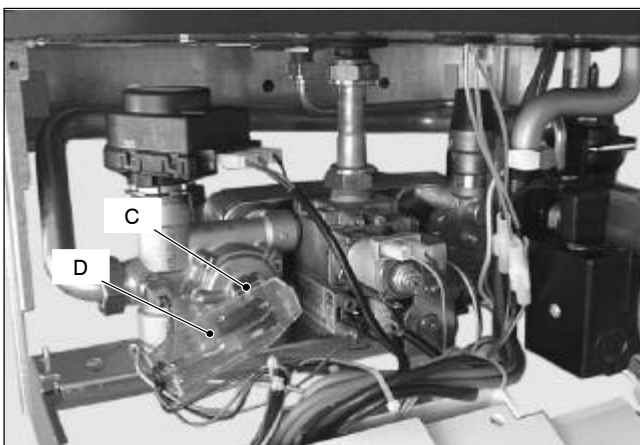

Fig. 49

12.2 Checks

Warning: isolate the boiler from the mains electricity supply before removing any covering or component.

✓ Mechanical function

- 1 Remove the front panel of the case.
- 2 Start and stop the boiler either in d.h.w. or c.h. mode.
- 3 Looking through the switch box verify the position of the shaft B referring to Fig. 50.

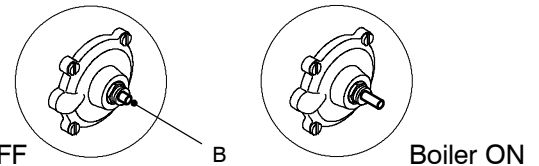

Fig. 50

✓ Electrical check

It is possible to verify the general operation of the switch by measuring the electric resistance between the contacts C. and N.O. of the switch.

- 1 Remove the switch as explained in section 12.3.
- 2 Measure the electrical resistance between the tabs marked C. and N.O. (Fig. 51). The contact must be normally open.
- 3 Operate the switch by hand and verify that the contact is now closed.

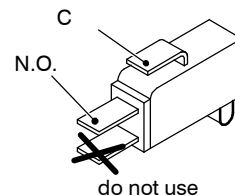

Fig. 51

12.3 Removal

Warning: isolate the boiler from the mains electricity supply before removing any covering or component.

✓ Removal of the switch

- 1 Remove the front and right hand side panels of the case.
- 2 Remove the fork C (Fig. 49).
- 3 Open the box and disconnect the switch.
- 4 Re-assemble the parts in reverse order of removal. Refer to Fig. 51 for the correct wiring connectors on the switch

✓ Removal of the membrane

- 1 Remove the front and right hand side panels of the case, turn off the flow and return isolation valves and empty the primary circuit.
- 2 Remove the fork C that holds the micro-switch housing D (Fig. 49).
- 3 Unscrew the four screws E (see Fig. 52) open the hydraulic operator and remove the membrane F.

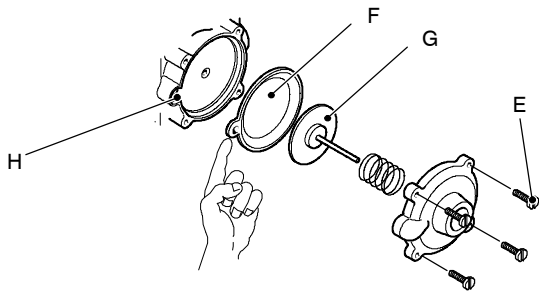

Fig. 52

4 Reassemble the parts in reverse order of removal.

When assembling the membrane, ensure that its concave side faces towards the actuator plate G and the reference indicated aligns with the seat H (see Fig. 52).

13 Expansion vessel and temperature–pressure gauge

13.1 Function

The Expansion vessel (I in Fig. 48) function is to allow for the volume expansion of the c.h. circuit water due to the temperature rise.

13.2 Checks

- 1 Turn off the flow and return isolation valves and empty the primary circuit of the boiler.
- 2 Remove the protective cap J (Fig. 53) from the valve on the top of the expansion vessel and connect a suitable air pressure gauge.

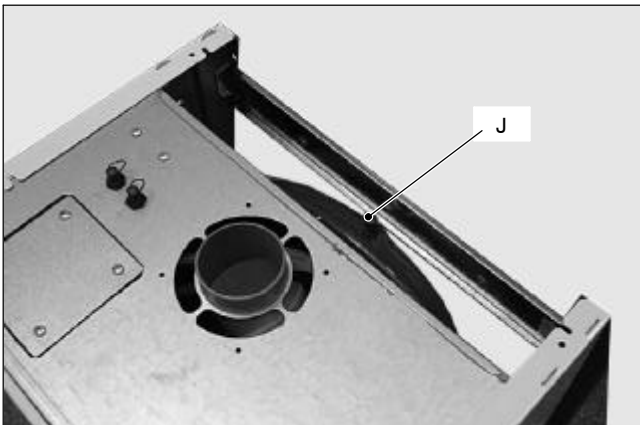

Fig. 53

3 Check the pre-load pressure and refer to the section *Expansion vessel* in the *User manual and installation instructions* for the correct value.

13.3 Removal of the expansion vessel

If there is at least 400 mm clearance above the boiler and the rear exit flue can be easily removed, the expansion vessel can be changed without removing the boiler.

Warning: isolate the boiler from the mains electricity supply before removing any covering or component.

- 1 Remove the front and left hand side panels of the case, turn off the flow and return isolation valves and empty the primary circuit.
- 2 Completely unscrew the connection K, the lock-nut L (Fig. 54) and remove the expansion vessel from the top of the boiler.

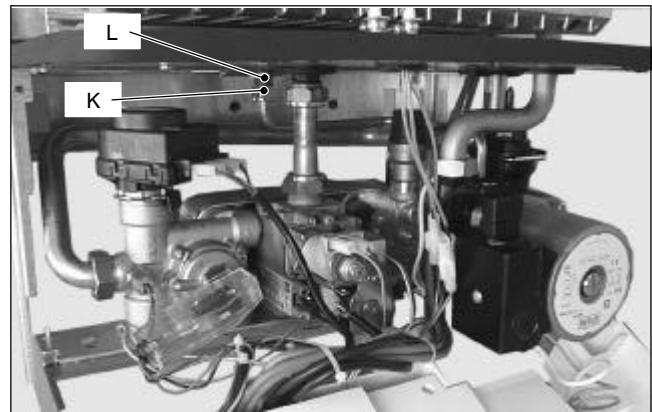

Fig. 54

3 Re-assemble the parts in reverse order of removal.

13.4 Removal of the temperature–pressure gauge

- 1 Remove the front and right hand side panels of the case, turn off the flow and return isolation valves and empty the primary circuit.
- 2 Remove the fork M and the probe holder spring N (Fig. 55).
- 3 Squeeze the tabs O to release the temperature–pressure gauge P and remove it.
- 4 Re-assemble the parts in reverse order of removal.

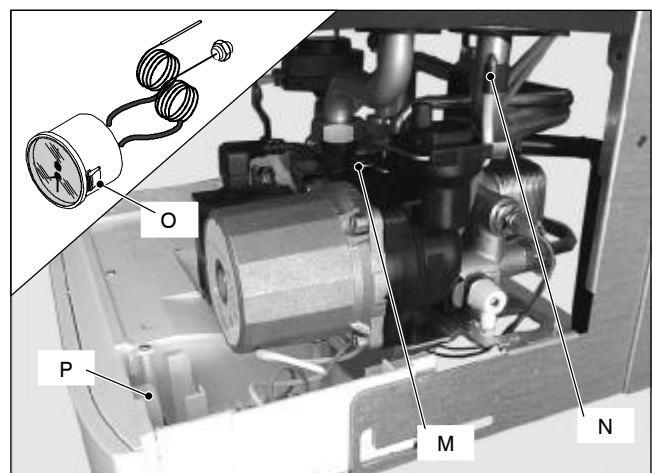

Fig. 55

14 D.h.w. flow switch, filter and flow limiter

14.1 Function

The d.h.w. flow switch *A* in Fig. 56 is a device that generates an electrical signal when hot water is drawn.

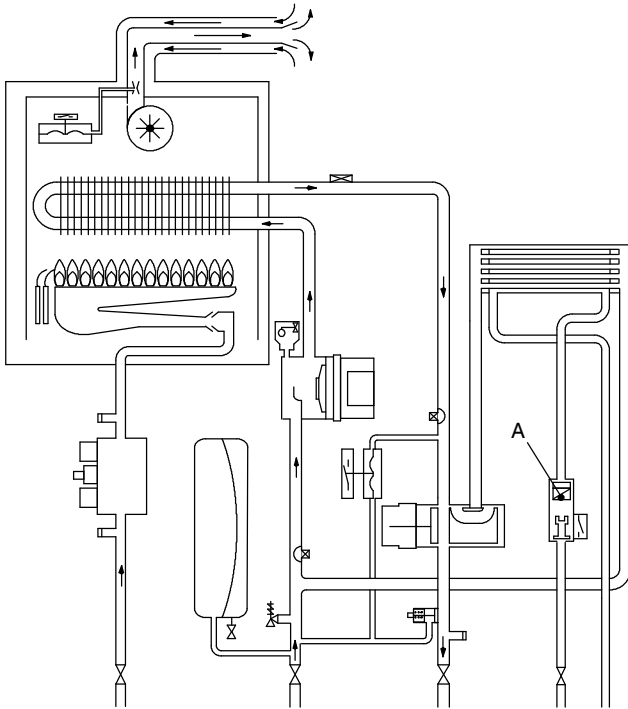

Fig. 56

When the flow rate through the d.h.w. circuit reaches about 2,5 litres/min', the float 4 (Fig. 58) is drawn towards the right.

The resulting magnetic field of ring 3 increases and reaches the flow switch sensor 1.

The sensor generates an electrical signal that switches the boiler d.h.w. operation ON.

The state of the sensor is also indicated by means of the lamp *B* placed on the sensor body.

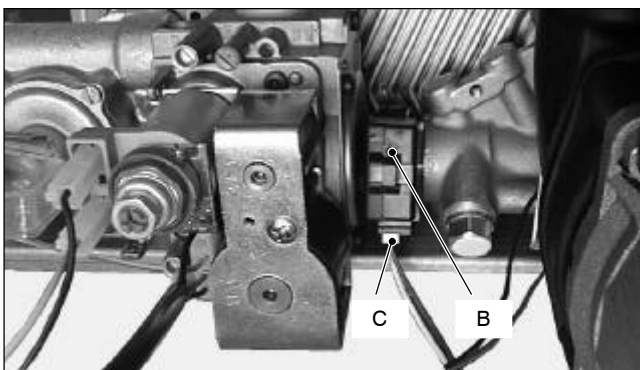

Fig. 57

14.2 Nomenclature and location of parts (Fig. 58)

- 1 Flow switch sensor
- 2 Plug
- 3 Magnetic ring
- 4 Float
- 5 Spring
- 6 Filter
- 7 Body
- 8 Spring seat
- 9 Flow limiter (M90D.28S optional accessory)
- 10 Threaded ring

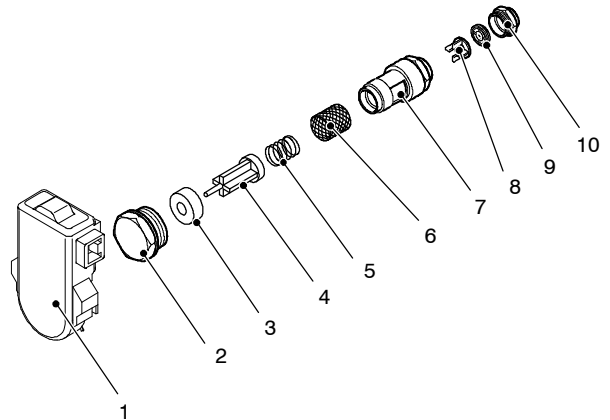

Fig. 58

14.3 Checks

Warning: isolate the boiler from the mains electricity supply before removing any covering or component.

✓ Flow switch sensor operation

- 1 Remove the front panel of the case.
- 2 Switch on the boiler and open a d.h.w. tap. The lamp *B* (Fig. 57) placed on the sensor body is switched on when the flow rate reaches about 2,5 litres/min'.

14.4 Removal of the flow switch sensor

Warning: isolate the boiler from the mains electricity supply before removing any covering or component.

- 1 Remove the front panel of the case.
- 2 Disconnect the connector *C* (Fig. 57) and remove the sensor by pulling it towards the front of the boiler (the sensor is held in place by means of a spring).

14.5 Removal of the flow switch group and d.h.w. circuit filter

Warning: isolate the boiler from the mains electricity supply before removing any covering or component.

- 1 Remove the front panel of the case and empty the d.h.w. circuit.

- 2 Remove the flow switch sensor (see section 14.4).
- 3 Remove the gas valve (see section 11.6).
- 4 Unscrew the plug 2 (Fig. 58) and extract the flow switch group.
- 5 To remove the filter from the flow switch group separate the body 7 from the plug 2 (Fig. 58) by unscrewing it.
- 6 Reassemble the parts following the removing sequence in reverse order.

Attention: the ring 3 (Fig. 58) has a magnetic polarity and must be correctly coupled with the spindle of the float 4.

To determine the correct orientation of the ring proceed as follows:

- 1 Set the function selector of the boiler in stand – by mode (Fig. 59).

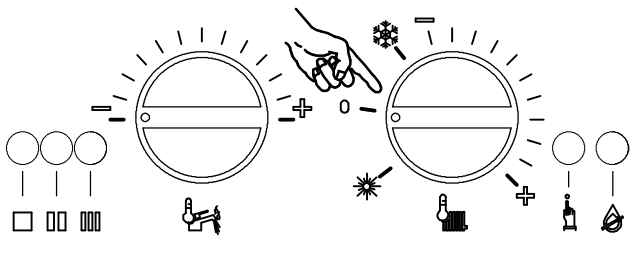

Fig. 59

- 2 Restore the mains electricity supply to the boiler. **Warning – ensure that all the electric parts and wirings are dry and do not touch other not mentioned electric parts during the following operations.**
- 3 Hold the flow switch sensor 1 and bring the ring in touch with the sensor as illustrated in Fig. 60.
- 4 Observe the lamp B placed on the sensor body that should light. If not reverse the ring and repeat the previous operation.

- 5 Fit the ring on the spindle of the float in the way that lights the lamp B.
- 6 Isolate the boiler from the mains electricity supply and reassemble the parts following the removing sequence in reverse order.

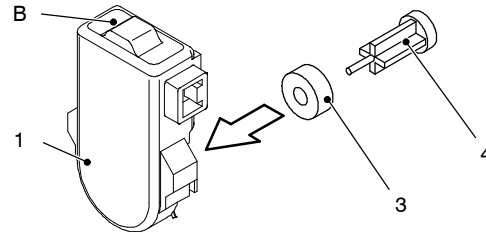

Fig. 60

14.6 Flow limiter

The M90D.24S model is factory fitted with a 10 litre/min. flow limiter.

If on the M90D.28S model the flow rate of the d.h.w. circuit is too high, it is possible to limit it by installing a flow limiter. The following sizes are available:

Nominal flow rate (litres/min)	Colour
10	Yellow
12	Brown

To install the flow limiter:

- 1 Remove the flow switch group as explained in the section 14.5.
- 2 Unscrew the threaded ring 10 (Fig. 58) and remove it from the body 7.
- 3 Install the flow limiter 9 putting its smaller diameter side towards the threaded ring.
- 4 Reassemble the group following the above sequence in reverse order.

15 Temperature probe

15.1 Function

The Temperature probe has the function of converting the temperature of the water in the hydraulic circuit where it is installed into an electrical signal (resistance).

The relation between temperature and electrical resistance is stated in Fig. 61.

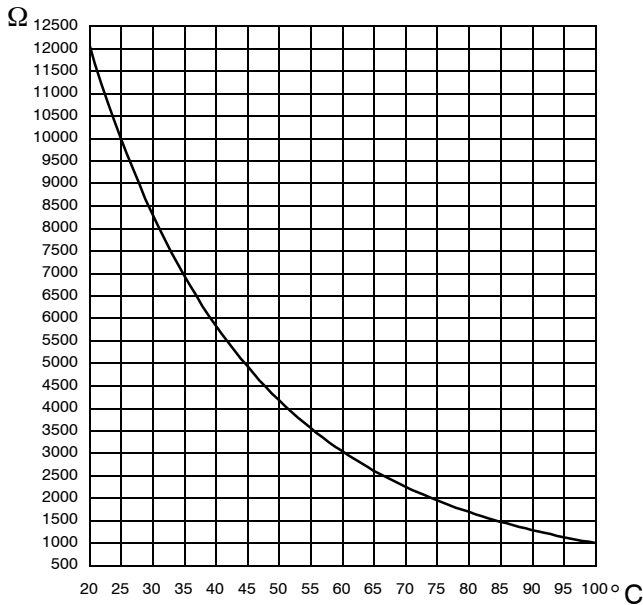

Fig. 61

On the boiler there are two Temperature probes. One on the output of the primary heat exchanger (c.h. Temperature probe) A in Fig. 62 and Fig. 63; one on its input, before the pump (d.h.w. Temperature probe) B in Fig. 62 and Fig. 64.

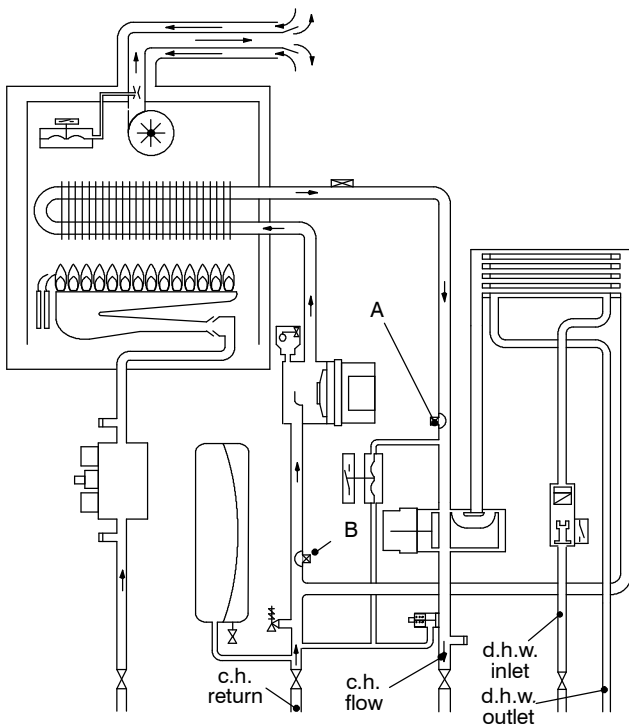

Fig. 62

15.2 Checks

✓ Temperature–resistance relationship

⚡ **Warning: isolate the boiler from the mains electricity supply before removing any covering or component.**

Disconnect the cable from the Temperature probe.

Measure the temperature of the brass group where the Temperature probe is located and check the electrical resistance according to the graph in Fig. 61.

15.3 Removal

⚡ **Warning: isolate the boiler from the mains electricity supply before removing any covering or component.**

Refer to Fig. 63 for the c.h. Temperature probe and to Fig. 64 for the d.h.w. Temperature probe.

- 1 To remove the Temperature probes remove the front and right hand side panels of the case.
- 2 Empty the primary circuit of the boiler.
- 3 Remove the electric connector of the Temperature probe and unscrew it.
- 4 Reassemble the Temperature probe carrying out the removal operations in reverse order.



Fig. 63



Fig. 64

16 By-pass valve

16.1 Function

The By-pass valve A in Fig. 65 is located between the c.h. water flow and return and its function is that of guaranteeing a minimum flow across the primary heat exchanger if the circulation across the c.h. system is completely closed.

The By-pass valve is fitted on the rear side of the diverter group.

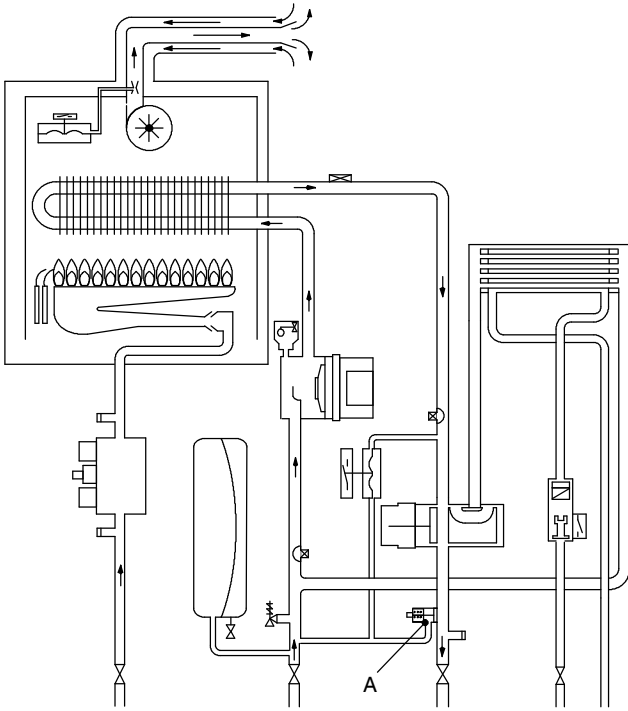

Fig. 65

16.2 Removal

Warning: isolate the boiler from the mains electricity supply before removing any covering or component.

- 1 Remove all the case panels.
- 2 Empty the primary circuit of the boiler.
- 3 Remove the diverter group as described in the section 8.4 of this manual.
- 4 Unscrew the connector B and remove the by-pass valve C (Fig. 66).

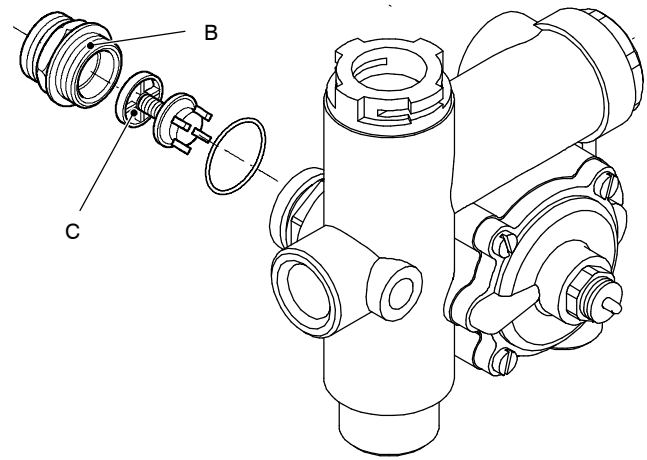

Fig. 66

- 5 Reassemble the by-pass valve as illustrated in Fig. 66 reversing the order of removal.

17 Fan, venturi device and Air pressure switch

17.1 Function

The function of the Fan is to force the products of combustion to the outside air via the flue system.

The Fan is supplied by the full sequence ignition device at the beginning of the ignition cycle.

Its correct functioning is controlled by means of a system incorporating a built in venturi device (A in Fig. 73) and an Air pressure switch.

17.2 Checks

✓ Check of the fan

⚡ **Warning: isolate the boiler from the mains electricity supply before removing any covering or component.**

- 1 Remove all the case panels and the sealed chamber lid.
- 2 Disconnect the connectors B (Fig. 67) and measure the electrical resistance of the motor that has to be about:
 47Ω – M90D.24S, M90D.24SR
 43Ω – M90D.28S, M90D.28SR
 (at ambient temperature).

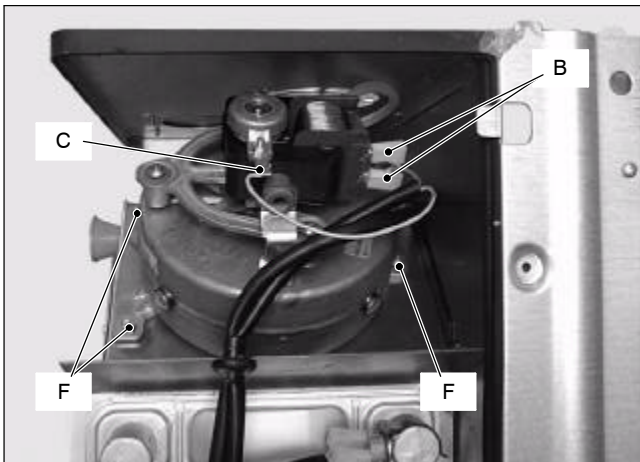

Fig. 67

✓ Check of the Air pressure switch operation

⚡ **Warning: isolate the boiler from the mains electricity supply before removing any covering or component.**

- 1 Remove all the case panels and the sealed chamber lid.
- 2 Disconnect the wires and check the electrical resistance between the connections of the Air pres-

sure switch.

Refer to the Fig. 68a or b in accordance with the type of air pressure switch used.

Between COM or 3 and N.O. or 2 the contact must be open.

Between COM or 3 and N.C. or 1 the contact must be closed (electrical resistance zero).

- 3 Connect the black wire (COM or 3) and the brown wire (N.C. or 1).
- 4 Run the boiler (the Fan must run) and check the the electric resistance between COM or 3 and N.O. or 2. Between COM or 3 and N.O. or "2 the contact must be closed (electrical resistance zero).

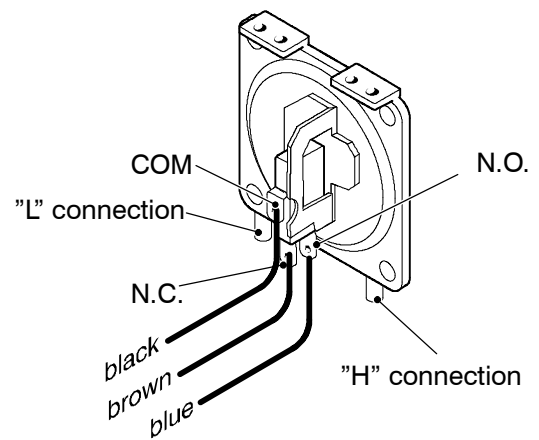

Fig. 68a

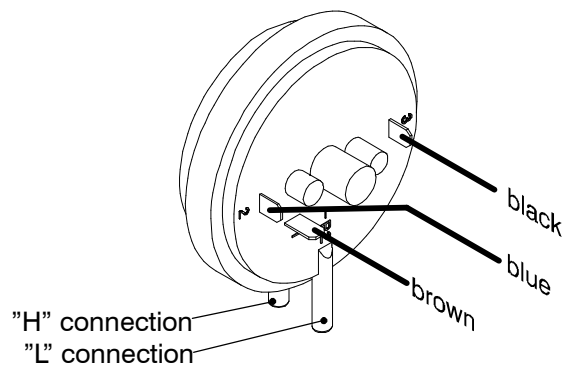

Fig. 68b

✓ Check of the venturi device

This test must be carried out with the sealed chamber closed

- 1 Remove the caps of the pressure test points located on the top of the boiler and connect a differential pressure gauge (Fig. 70).
- 2 Switch on the boiler.

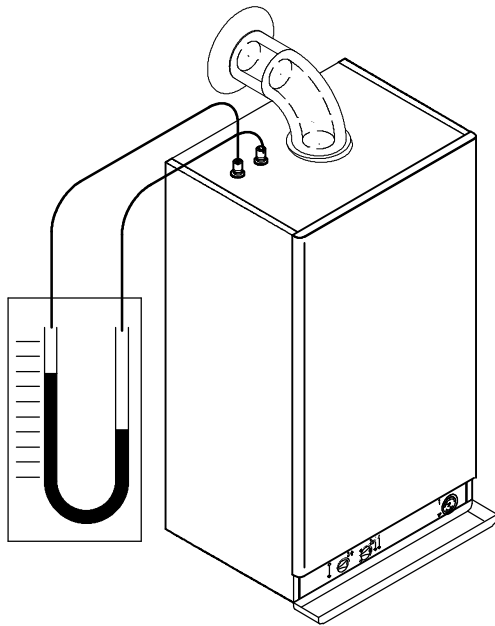

Fig. 70

- 3 Compare the value on the gauge with the following minimum values:

90 Pa (0,9 mbar) – M90D.24S, M90D.24SR
 100 Pa (1,0 mbar) – M90D.28S, M90D.28SR

17.3 Removal of the Fan

Warning: isolate the boiler from the mains electricity supply before removing any covering or component.

- 1 Remove all the case panels, the sealed chamber lid and the combustion chamber lid.
- 2 Disconnect the connectors *B* and the earth connection *C* (Fig. 67).
- 3 Disconnect the pipe which connect the venturi device to the Air pressure switch.
- 4 Unscrew the screws *D* and remove the clamp *E* (Fig. 71).

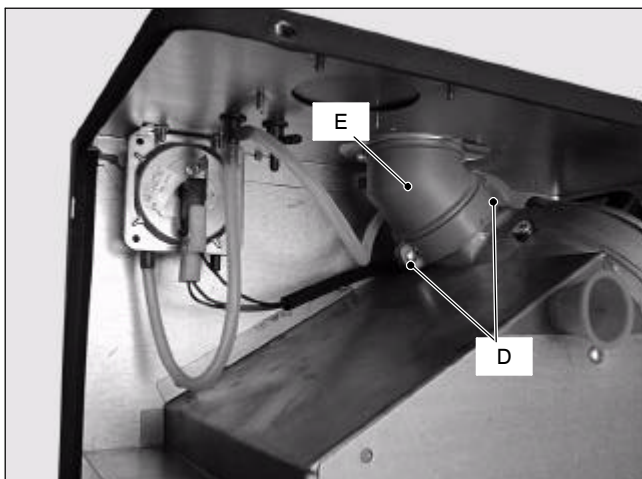

Fig. 71

- 5 Remove the three screws *F* (Fig. 67) securing the Fan to the flue hood and remove the fan.

- 6 Assemble the fan carrying out the removal operations in reverse sequence.

Warning: to correctly connect the venturi device to the Air pressure switch, refer to Fig. 72.

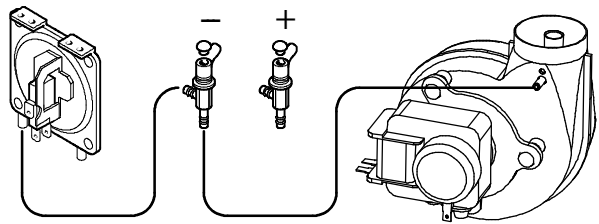

Fig. 72

Warning: After cleaning or replacement as detailed above refer to section *Combustion analysis check* in the chapter *Maintenance of the installation instructions manual*.

17.4 Inspection and removal of the venturi device

Warning: isolate the boiler from the mains electricity supply before removing any covering or component.

- 1 Remove the fan (section 17.3).
- 2 Remove the venturi device by unscrewing the screw *G*.
- 3 Inspect the venturi device *A* and the connection pipe *H*. Ensure they are clean.
- 4 Re-assemble the parts in reverse order of removal.

Warning: After cleaning or replacement as detailed above refer to section *Combustion analysis check* in the chapter *Maintenance of the installation instructions manual*.

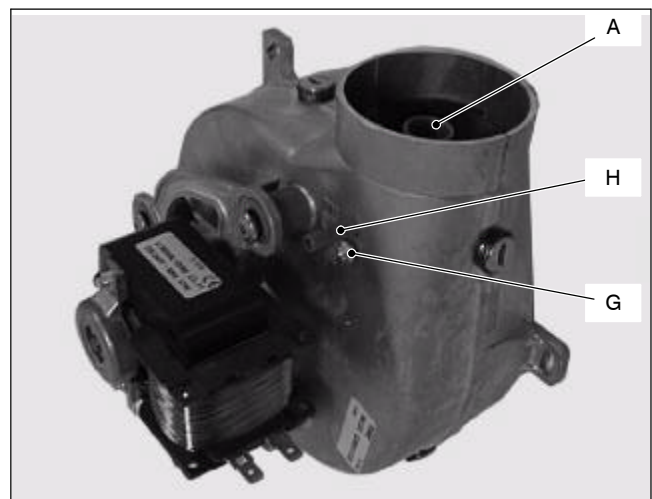



Fig. 73

17.5 Removal of the Air pressure switch

 **Warning: isolate the boiler from the mains electricity supply before removing any covering or component.**

- 1 Remove all the case panels and the sealed chamber lid.
- 2 Disconnect the wires from the Air pressure switch.
- 3 Remove the pipe from the Air pressure switch.

- 4 Unscrew the screws which hold the Air pressure switch to the frame.
- 5 Assemble the Air pressure switch carrying out the removal operations in reverse sequence.

Warning: to correctly connect the Air pressure switch, refer to Fig. 72 and Fig. 68a or Fig. 68b for the correct wiring.



Warning: After cleaning or replacement as detailed above refer to section *Combustion analysis check* in the chapter *Maintenance of the installation instructions manual*.

18 Ignition and detection electrodes

18.1 Function

Three electrodes are fitted on the burner. Two of them are the ignition electrodes and are fitted near the front part of the burner. The ignition sparks take place between their metallic edges over the central ramp of the burner during the ignition sequence.

The third electrode is the detection electrode and it detects the presence of the flame.

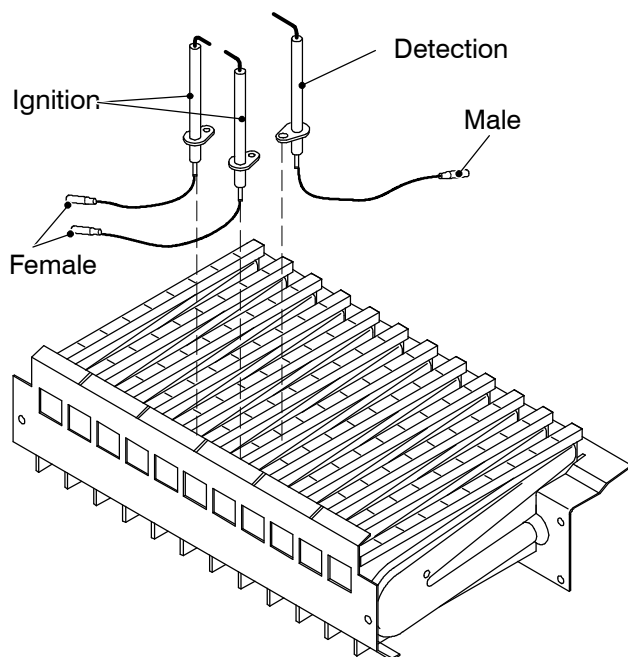

Fig. 74

18.2 Checks

✓ Check the position of the electrode edges

⚡ **Warning: isolate the boiler from the mains electricity supply before removing any covering or component.**

- 1 Remove all the case panels, the sealed chamber lid and the combustion chamber lid.
- 2 Check for the correct distance between the metallic edges of the ignition electrodes (see Fig. 75).

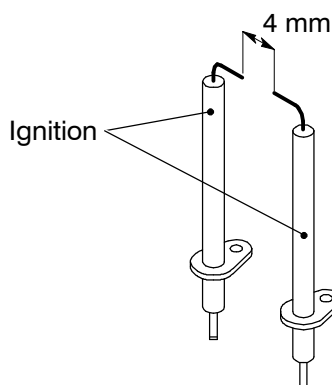

Fig. 75

- 3 Check the integrity of the detection electrode and ensure that its metallic edge is correctly placed over the ramp of the burner.

✓ Check the connection wires.

⚡ **Warning: isolate the boiler from the mains electricity supply before removing any covering or component.**

- 1 Remove all the case panels, the sealed chamber lid and the combustion chamber lid.
- 2 Check for the integrity of the insulation of wires which connect the electrodes to the ignition device.

18.3 Removal

⚡ **Warning: isolate the boiler from the mains electricity supply before removing any covering or component.**

- 1 Remove all the case panels, the sealed chamber lid and the combustion chamber lid.
- 2 Disconnect the electrode wires from the full sequence ignition device.
- 3 Remove the burner by unscrewing the four screws placed at the right and left sides of the burner.
- 3b For models M90D.28S and M90D.28SR, remove also the plate C (see Fig. 78 on page 39).
- 4 Unscrew the screws A (Fig. 76) which hold the electrodes to the burner.

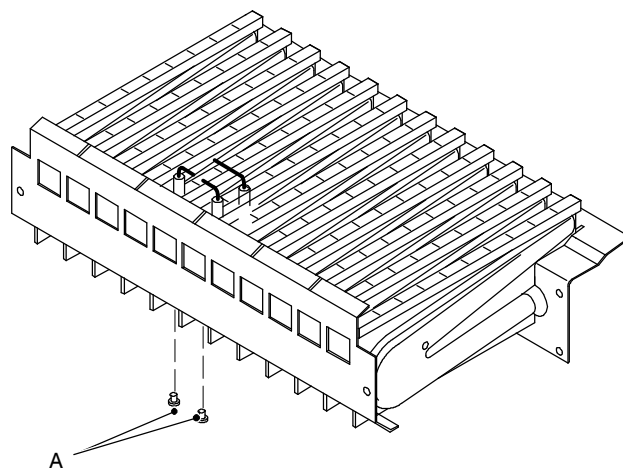

Fig. 76

- 5 Extract the electrodes from the burner.
- 6 Assemble the electrodes carrying out the removal operation in reverse order. Refer to Fig. 74 in order to recognise the electrodes and to correctly connect the wiring.

Note: the metallic edge of the detection electrode is longer than the one of the ignition electrodes.

⚠ **Warning: After cleaning or replacement as detailed above refer to section *Combustion analysis check* in the chapter *Maintenance of the installation instructions manual*.**

19 Safety thermostat

19.1 Function

The safety thermostat *A* in Fig. 77 is a device that senses the temperature of the primary circuit water which flows in the outlet pipe of the primary heat exchanger.

If the temperature control system of the boiler fails and the temperature of the primary circuit reaches a dangerous temperature, the safety thermostat opens the electric circuit that supplies the on-off operators of the gas valve.

Consequently, the full sequence ignition device attempts to light the burner and, at the end, locks the boiler and lights the lock-out signal lamp.

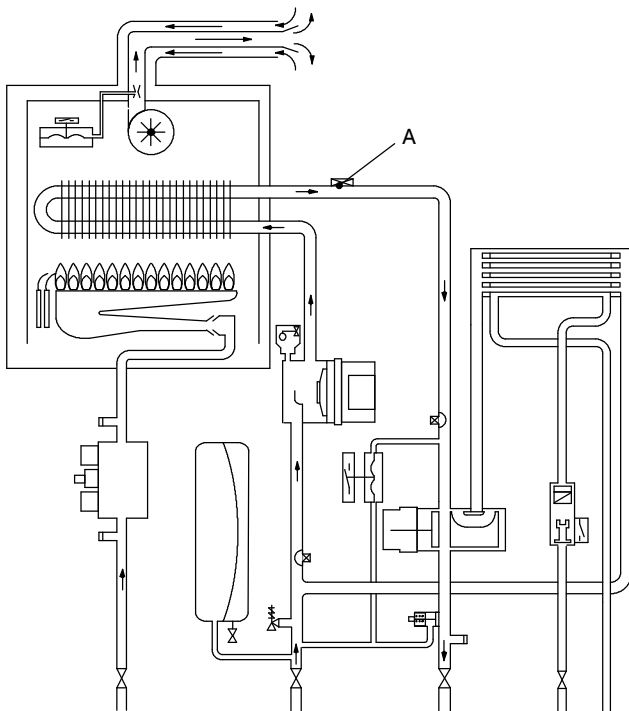

Fig. 77

19.2 Checks

Warning: isolate the boiler from the mains electricity supply before removing any covering or component.

Overheat temperature value

- 1 Set the temperature control knobs to their max. position and run the boiler in d.h.w. and c.h.
- 2 Allow the boiler to reach its maximum operating temperature (monitor the temperature gauge on the instrument panel). The boiler should maintain a temperature below that of the safety thermostat and no overheat intervention should occur.

Electrical function

- 1 Remove all the case panels and the lid of the sealed chamber.
- 2 Disconnect the safety thermostat and check its electrical function. Normally (no intervention) the

contact must be closed (electrical resistance zero Ω).

19.3 Removal

Warning: isolate the boiler from the mains electricity supply before removing any covering or component.

- 1 Remove all the case panels and the lid of the sealed chamber.
- 1b For models M90D.28S and M90D.28SR, remove the screw *B* and the plate *C* (Fig. 78).

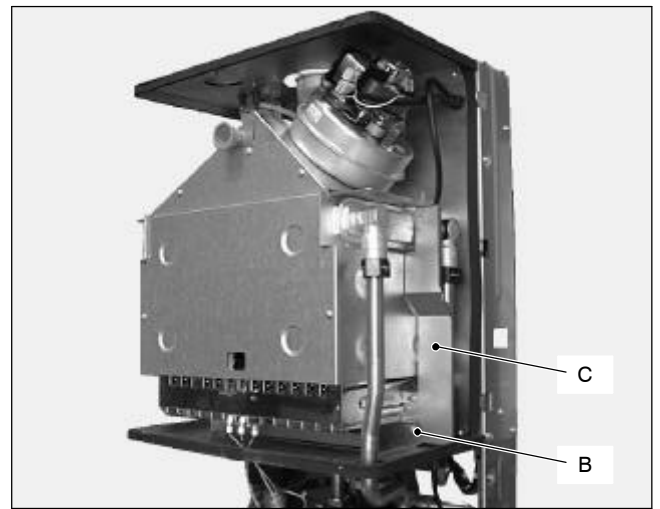

Fig. 78

- 2 Disconnect the wiring *D* (Fig. 79).
- 3 Remove the spring *E* which holds the overheat thermostat on the pipe of the primary heat exchanger and remove it.

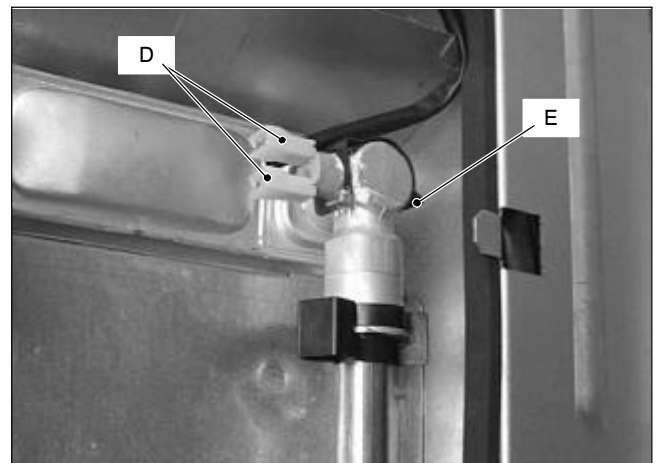

Fig. 79

- 4 Reassemble the overheat thermostat carrying out the operations in reverse order.
- 5 Apply an adequate quantity of heat conducting compound between the pipe and the thermostat.

Warning: After cleaning or replacement as detailed above refer to section **Combustion analysis check** in the chapter **Maintenance of the installation instructions manual**.

20 Short spare parts list

Key	G.C. part no.	Description	Q.ty	Manufac- turer part no.	Manufacturer's reference
1	173–148	Burner (mod. M90D.24S, M90D.24SR)	1	KI1004 102	Polidoro
	173–149	Burner (mod. M90D.28S, M90D.28SR)	1	KI1004 147	
2	169–069	Injectors for natural gas (mod. M90D.24S, M90D.24SR)	12	KI1064 505	Polidoro
		Injectors for natural gas (mod. M90D.28S, M90D.28SR)	14		
	169–070	Injectors for LPG (mod. M90D.24S, M90D.24SR)	12	KI1064 506	
		Injectors for LPG (mod. M90D.28S, M90D.28SR)	14		
3		Expansion vessel	1	BI1182 105	CIMM 7 litres
4		Main heat exchanger (mod. M90D.24S, M90D.24SR)	1	BI1202 101	
		Main heat exchanger (mod. M90D.28S, M90D.28SR)	1	BI1202 102	
5		Fan (mod. M90D.24S, M90D.24SR)	1	BI1366 102	FIME GR02040 39W
		Fan (mod. M90D.28S, M90D.28SR)	1	BI1366 103	FIME GR02045 47W
6	E83–129	Gas valve	1	BI1193 105	SIT 845 Sigma
7	169 127	Air pressure switch 0,88–0,74 mbar (mod. M90D.24S, M90D.24SR)	1	KI1267 103	Yamatake–Honeywell C6065 SIT 380 (alternative)
		Air pressure switch 1,04–0,92 mbar (mod. M90D.28S, M90D.28SR)	1	BI1366 107	Yamatake–Honeywell C6065 Sit 380 (alternative)
8	E83–013	Safety valve	1	BI1131 100	Watts Orkly (alternative)
9	E83–178	Combustion chamber side panels	2	BI1326 100	
10	E83–180	Combustion chamber rear panel (mod. M90D.24S, M90D.24SR)	1	BI1326 107	
	E83–181	Combustion chamber rear panel (mod. M90D.28S, M90D.28SR)	1	BI1326 108	
11	E83–196	Combustion chamber front panel (mod. M90D.24S, M90D.24SR)	1	BI1326 101	
	E83–197	Combustion chamber front panel (mod. M90D.28S, M90D.28SR)	1	BI1326 102	
12		Electronic regulation p.c.b.	1	BI1515 107	
13	E83–142	Full sequence ignition device	1	BI1305 101	Bertelli & Partners FM30 Honeywell FPLD (alternative)
14	E01–205	D.h.w. heat exchanger	1	BI1001 102	
15		Pump	1	BI1272 100	WSC– NFSL 12/5
16	E00–684	Primary circuit flow switch	1	BI1011 505	
17	E83–082	D.h.w. flow switch	1	BI1091 104	
18	E00–688	Main. flow switch membrane	1	BI1011 103	
19	E83–086	Three way diverter valve (electric actuator)	1	BI1101 102	Elbi
20	E83–101	Overheat thermostat	1	BI1172 105	ELTH – type 261
21	169–083	Fuse 1,6 A T	1	BI1005 105	
22	164–026	Temperature probe (main or d.h.w. circuit)	1	BI1001 117	
23	E83–127	Ignition electrode (left)	1	BI1123 101	
24	E83–126	Ignition electrode (right)	1	BI1123 103	
25	E83–122	Detection electrode	1	BI1123 102	
26	E83–145	Temperature–pressure gauge	1	BI1475 108	IMIT

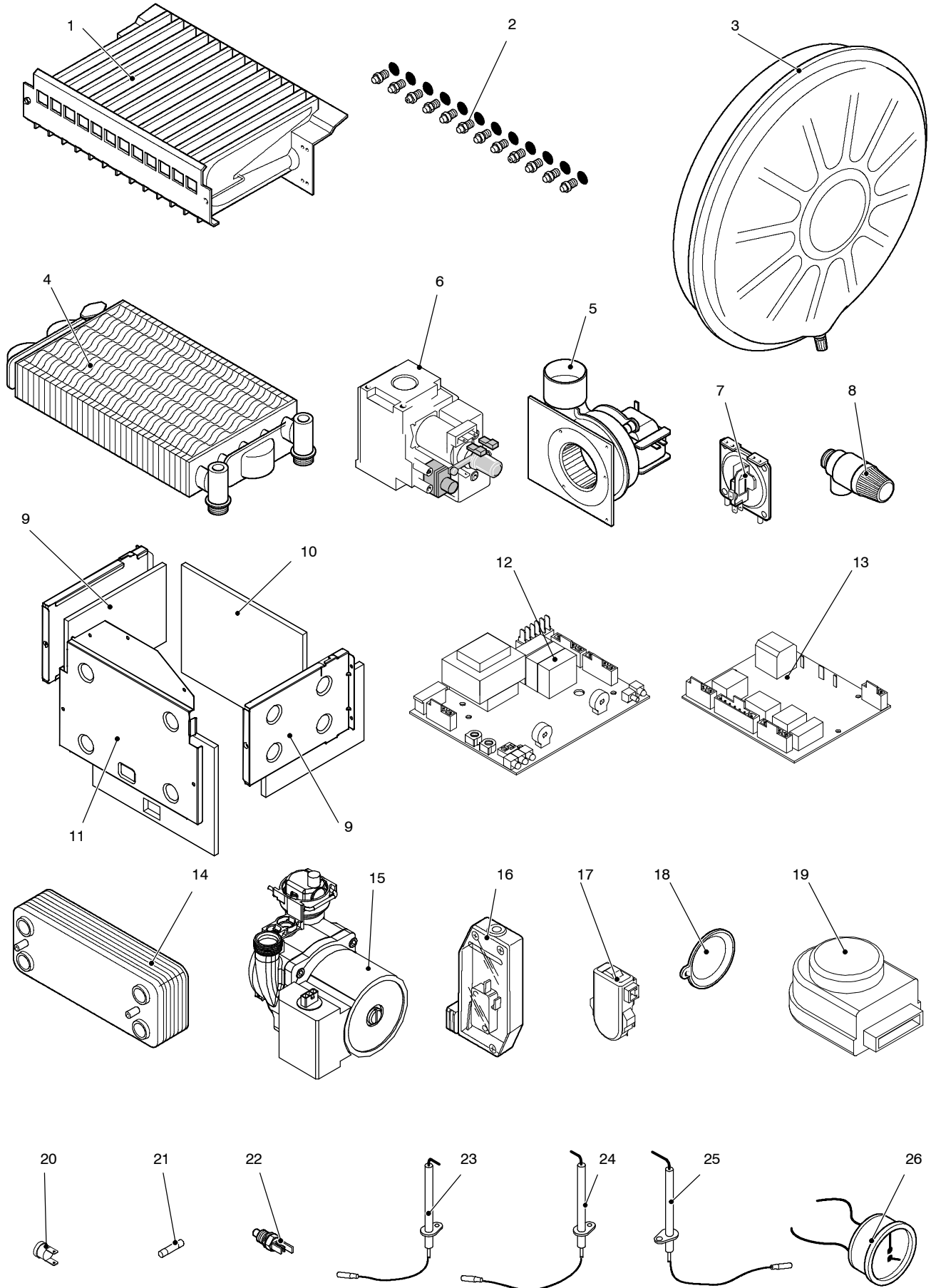



17962.0914.6 3804 44A4 UK